



eReflex Electric Range

Inset LED Fire



Instructions for Use, Installation & Servicing

For use in AU & NZ (Australia & New Zealand).



IMPORTANT

THE OUTER CASING, FRONT AND GLASS PANEL BECOME EXTREMELY HOT DURING OPERATION AND WILL RESULT IN SERIOUS INJURY AND BURNS IF TOUCHED. IT IS THEREFORE RECOMMENDED THAT A FIREGUARD IS USED IN THE PRESENCE OF YOUNG CHILDREN, THE ELDERLY OR INFIRM.

For use with 220-240V 50Hz electricity supply only.

Please read these instructions carefully before installation and keep them in a safe place.

They will be needed when maintenance or servicing is required.

THIS APPLIANCE MUST BE EARTHED

Contents

Covering the following models:

eReflex Inset 55R	eReflex Inset 75R	eReflex Inset 85R	eReflex Inset 105R	eReflex Inset 135R	eReflex Inset 195R
210-063AZ	210-071AZ	210-009AZ	210-017AZ	210-023AZ	210-031AZ

User Instructions.....3

- 1. Important Information & Health and Safety..... 3
- 2. Operating Instructions..... 3
- 3. Maintenance..... 8

Installation Instructions.....10

- Technical Specifications..... 10
- Appliance Dimensions..... 11

Installation.....12

- 1. General..... 12
- 2. Fitting The Appliance..... 12
- 3. Studwork Installation..... 12
- 4. Removing the Exterior Glass..... 14
- 5. Fuel Effect..... 15
- 6. Completion of Assembly..... 18

Servicing19

- 1. Fault Finding..... 19
- 2. Servicing Requirements..... 19
- 3. Removing the Exterior Glass..... 19
- 4. Removing the LED Light Bar..... 20
- 5. Replacing the Interior Glass Panels..... 20
- 6. Removing the Fuel Bed..... 21
- 7. Replacing the Fuel Bed Effects Spindle..... 22
- 8. Replacing the Fuel Bed LED Boards..... 22
- 9. Replacing the Interior Glass Screen..... 23
- 10. Replacing the Effects Screen..... 24
- 11. Replacing the Flame Effects Spindle..... 24
- 12. Replacing the Flame Effects LED Board..... 25
- 13. Replacing the Fuel Bed Motor..... 26
- 14. Replacing the Flame Effects Motor..... 26
- 15. Replacing the Power Unit..... 27
- 16. Replacing the Heater Assembly..... 27
- 17. Pairing the Remote Control to the Appliance..... 28
- 18. Resetting the Remote..... 28

Wiring Diagram.....29

Spare Parts List.....30

WARRANTY

This system carries a 12 month parts-labour warranty. Please note that all warranties are effective from the date of purchase.



Tested to AS/NZS 60335.2.30:2015 &
AS/NZS 60335.1:2011
Certificate Number AZ69022563

1. Important Information and Health and Safety

- 1.1 **Read all of the instructions carefully before using the appliance.**
- 1.2 **Remove all packaging and dispose of at an appropriate recycling facility.**
- 1.3 Do not locate this appliance immediately below a fixed socket outlet.
- 1.4 Do not use this appliance in the immediate surroundings of a bath, shower, swimming pool or any other area where the appliance could come into contact with water or humidity, e.g. a bathroom.
- 1.5  **WARNING! DO NOT COVER**
Do not allow the appliance to be covered or let the air inlet/outlet become obstructed as the appliance may overheat. Please note the warning symbol on the appliance (see above).
- 1.6 **For indoor use only.** This appliance is not suitable for use outside the house.
- 1.7 This appliance must be installed in a purpose built studwork enclosure. Ensure the appliance is level and that furniture, curtains etc. are positioned no closer than 1m.
- 1.8 Where the electricity supply cable has to pass through a fire place, stone surround etc. ensure suitable rubber bushes are fitted at possible wear points.
- 1.9 Keep the power cord away from hot surfaces and hot conditions. Do not route the power lead in front of the appliance.
- 1.10 When the fire has been installed the position of the plug must be accessible.
- 1.11 If the electricity supply cable is damaged do not use the appliance until it has been replaced. For safety reasons the replacement has to be carried out by a suitably qualified person.
- 1.12 **CAUTION:** In order to avoid a hazard due to inadvertent resetting of the thermal cut-out, this appliance must not be supplied through an external switching device, such as a timer, or connected to a circuit that is regularly switched on and off by the utility.
- 1.13 Do not operate the appliance if it is damaged.
- 1.14 Repairs of electrical appliances must only be performed by a suitably qualified person. Should the appliance fail to operate, or in case of any damage, please contact the retailer from whom the appliance was purchased.
- 1.15 This appliance can be used by children aged from 8 years and above and persons with reduced physical, sensory or mental capabilities or lack of experience and knowledge if they have been given supervision or instruction concerning use of the appliance in a safe way and understand the hazards involved. Children of less than 3 years should be kept away unless continuously supervised.

Children aged from 3 years and less than 8 years shall only switch on/off the appliance provided that it has been placed or installed in its intended normal operating position and they have been given supervision or instruction concerning use of the appliance in a safe way and understand the hazards involved. Children aged from 3 years and less than 8 years shall not plug in, regulate and clean the appliance or perform maintenance.

However Gazco recommend:

This appliance is not intended to be used by persons under the age of 12, persons with reduced physical, sensory or mental capabilities or persons with lack of experience and knowledge in the safe operation of the appliance.

The appliance may be operated by persons above the age of 12 provided they have been instructed in the safe use of the appliance and that they understand the hazards involved. Persons above the age of 12 may also operate the appliance under the supervision of a responsible adult.

Parts of this appliance become hot whilst in operation and under no circumstances should persons under the age of 12 be left alone with the product when it is in operation unless a suitable fireguard is used to protect them against the possibility of coming into direct contact with the appliance.

Children shall not play with the appliance.

Cleaning and user maintenance shall not be made by children without supervision.

2. Operating Instructions



WARNING! Do not operate the appliance if it is damaged or has malfunctioned. If you suspect the appliance is damaged or has malfunctioned call a suitably qualified person to inspect the appliance, and replace any part of the electrical system if necessary, before reuse.

Do not disconnect the power at the mains supply whilst the appliance is running. Use the functions on the remote to turn the fire off and ensure the mains switch has been moved to the off position before disconnecting.

GENERAL

- 2.1 The appliance can be operated by the radio frequency handset or the manual controls which are on the right hand side of the viewing window.



NOTE: To use both remote and manual functions the manual on/off switch must be in 'ON' position. In order to prevent the product becoming too hot, there is a 10s delay when turning on the heater and a 10s delay when turning off the heater fan.

The manual button controls basic functions, not a full range of controls. Use the remote hand set to carry out all functions.

User Instructions

PREPARATION BEFORE USE

Batteries:

- 2.2 Ensure that the handset batteries are new and inserted correctly.
- 2.3 Dispose of old batteries at an appropriate recycling facility.

LOCATION OF POWER SWITCH

- 2.4 The mains power switch is located on the control panel located on the right-hand side of the viewing window, see Section 2a.
- 2.5 Switch ON (—) before operating either the remote or manual controls.
- 2.6 A long beep is heard to indicate the fire is ready for use.

2a. Manual Control Panel

- 2a.1 The manual controls on appliance are located at the upper right of appliance.
- 2a.2 Turning on the appliance with the main power switch on '—' position. A long beep will be heard.
- 2a.3 Press "LIGHTS ON/OFF" to turn on or turn off both the flame and fuel bed at the same time.
- 2a.4 There are 3 flame colour options:

Press "FLAME" button to select the colour of flame or return to the OFF position.
- 2a.5 There are 14 fuel bed colour options:

Press "FUEL BED" button to select the colour of fuel bed or return to the OFF position.

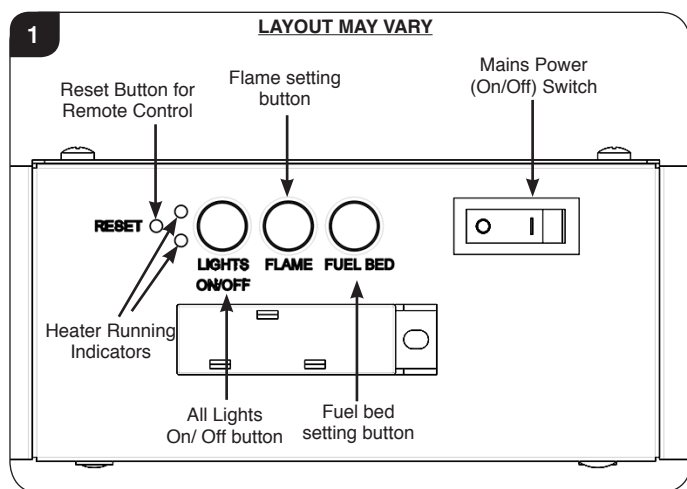

Note: The appliance will lose the memory for the light functions when the switch is set to the Off Position or the remote runs out of power.

Heater Running Indicators (see Diagram 1)

- 2a.6 When the fan heater is used in conjunction with the flame or fuel bed effects the heater running indicators will light up for 10 seconds.

The LEDs will illuminate for 10 seconds if the flame or fuel bed effect is On.

If the fan heater is used independently, the heater running indicators will stay on.

Reset Button for Remote Control

- 2a.7 If the handset loses signal or needs to be replaced then, see Section 18 in Servicing Section for details.

2b. Remote Controls

The remote control should be left on a flat surface in the room where the appliance is installed and away from any direct flow of hot air.

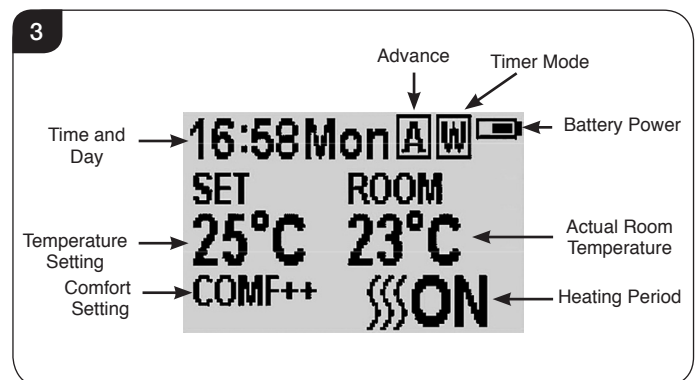
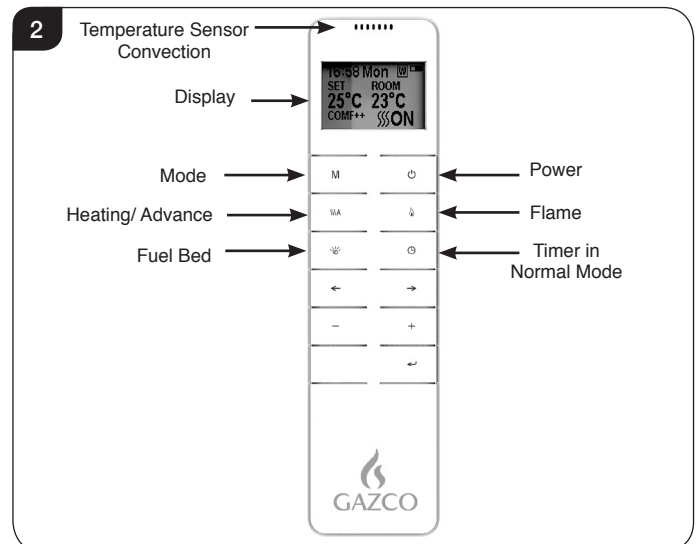



Signal Code

- 2b.1 The remote control works by radio signal. The handheld transmitter is configured in the factory with a unique signal code.

IMPORTANT: If the handset loses signal or needs to be replaced, see Section 18 in Servicing Section for details.

User Instructions

Turn on/off

- 2b.2 Press  button to turn on the flame effect.
- 2b.3 Press  button to turn off all the functions under the normal heating control mode including flame effect and fan heater.
- 2b.4 Press  button to turn off the flame effect under daily and week timer heating mode.

Week Days/ Time/ Comfort Temperature and Unit Setting

On activation it is recommended that the clock is reset to the correct time to ensure accuracy of the appliance operation.

- 2b.5 Hold the **M** button for 3 seconds to enter the setting screen.
- 2b.6 Press the '←' or '→' button to choose setting to change.

The selected character will be highlighted, see Diagram 4.



- 2b.7 Press the '+' or '-' button to adjust the number.

Time: 24-hour system.
 Select Comfort temperature from 15-25°C.
 Temperature unit: °C/°F.

- 2b.8 Press the  button for 3 seconds or wait 10 seconds to save and exit the week, time and heating temperature setting.

Daily Timer Heating

- 2b.9 The following heating periods have been preset, these can be altered if desired:

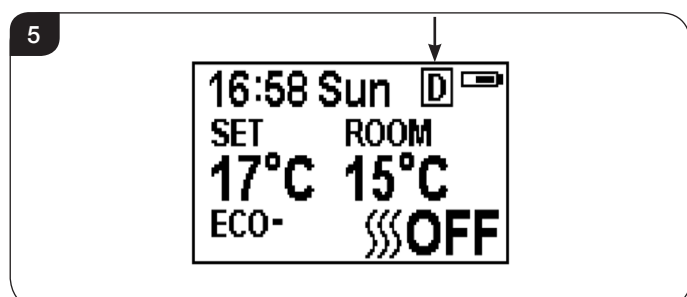

06:00 until 08:00
 17:00 until 22:00

- 2b.10 Press **M** until **D** shows at the upper right corner of the screen to enter the daily timer heating mode.

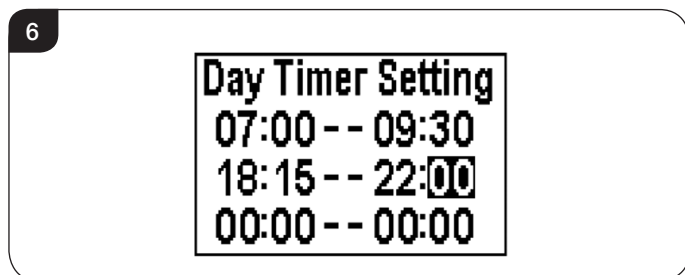

- 2b.11 Hold the  button for 6 seconds to enter the daily heating setting.
 A maximum of 3 timed heating periods can be set per day.
- 2b.12 Press '←' or '→' to choose hour or minute.
- 2b.13 Press '+' or '-' to set the number.
 The minute increment / decrement by 15min per press.



- 2b.14 Hold the  button for 3 seconds or wait for 10 seconds to save and exit the heating time period setting.
- 2b.15 Check the timer setting. Press  to check the daily timer mode.
- 2b.16 If the heating needs to be turned off, it will be necessary to go back to the Normal Control Mode to it turn off.

When in Daily Timer Mode switching the appliance off with the remote will stop the light output. The heat output will continue according to the timer settings.

Adjusting the Set Temperature

- 2b.17 Press the '+' or '-' button to increase or decrease the temperature on the basis of COMF temperature.

COMF means the actual temperature is the same as setting.

ECO means the actual temperature is 2°C lower than the setting temperature.

ECO- means 4°C lower.

COMF+ means 2°C higher.

COMF++ means 4°C higher.

Adaptive start control

According to room temperature and set-pointed temperature, the heater will automatically determine the appropriate time to heat to ensure that it will reach the set-pointed temperature in the set time (up to 45 minutes prior to the set time).

User Instructions

Flame Colour Adjustment

2b.18 Press  button to enter the flame adjustment screen.

There are 3 flame colour options, indicated by the number shown in Diagram 7.

There are 6 levels of brightness, including off. This is indicated by the bar, with the blank bar indicating off, see Diagram 7.

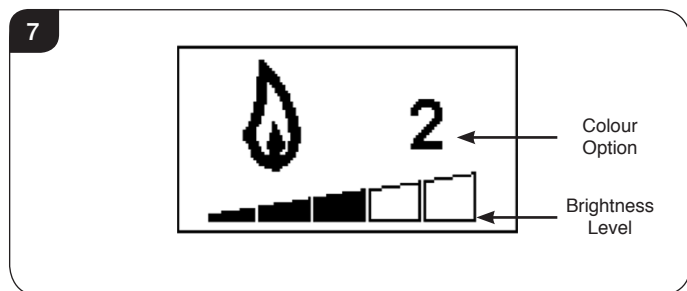

2b.19 Press the '←' or '→' button to cycle through the flame colour options.

2b.20 Press the '+' button to increase the flame brightness.

Press the '-' button to decrease the flame brightness until off.

Fuel Bed Colour Adjustment

2b.21 Press  to enter the fuel bed light adjustment screen.

There are 14 fuel bed colour options, indicated by the number shown in Diagram 8.

There are 6 levels of brightness, including off. This is indicated by the bar, with the blank bar indicating off, see Diagram 8.

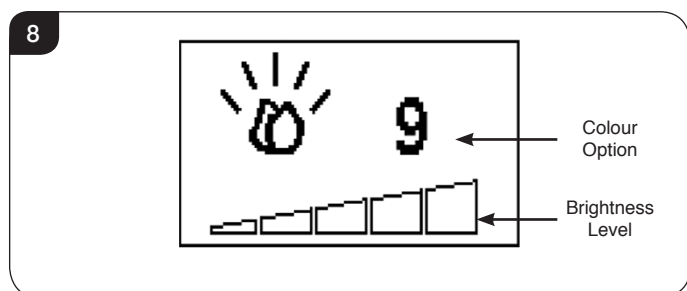

2b.22 Press the '←' or '→' button to cycle through the fuel bed colour options.

2b.23 Press the '+' button to increase the fuel bed brightness.

Press the '-' button to decrease the fuel bed brightness until off.



Normal Control Mode

2b.24 Normal Control Mode is the default setting.

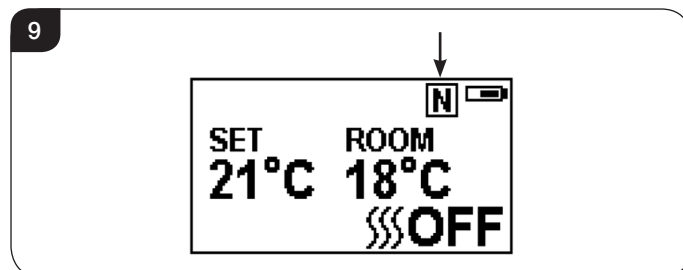
Alternatively press **M** button until the **N** logo is shown at the upper right corner of the screen, see Diagram 9.



2b.25 Press the '+' or '-' button to adjust the setting temperature from 17 °C to 25°C.

2b.26 Press  **A** button to turn the heat on/off,  ON or  OFF will show at the lower right corner of the screen, see Diagram 10.

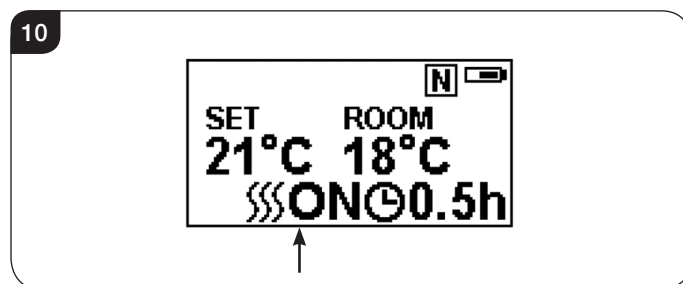

Note: It is normal for the fan heater to stop running for periods of time. This happens if the room temperature is higher than the temperature set on the control.

The heater indicator will be turned off after 10s if the flame is switched ON. The heater indicator will stay ON if only the heating function is used.

When in Normal Control Mode switching the appliance off with the remote will stop both the light and heat output.

Count Down Timer



This setting is only in normal heating control mode. It allows the appliance to be returned to Standby after a set period of time. The heater must be switched on to use this function.

2b.27 Press  to cycle through the setting from Off and 0.5 hours to 9 hours. Timer logo and remaining time will show on the screen.

The heater of appliance can be automatically run by using daily timer and weekly timer on the remote.

Battery

The battery power level is indicated at the top right of the remote control screen, see Diagram 3.

	Battery Full	No action required
	Battery Half Power	Ensure new batteries are available.
	Battery Empty	Replace batteries immediately

Battery replacement is recommended after 1 year. The Remote requires two 1.5V alkaline AAA batteries.

Changing the batteries will not affect the Timer Mode settings, however, the clock may need adjusting.

Week Timer Heating

2b.28 The following heating periods have been preset, these can be altered if desired:

From Monday to Friday
06:00 until 08:30
17:00 until 22:00

From Saturday to Sunday
06:30 until 09:30
11:00 until 13:00
17:00 until 22:00

2b.29 Press **M** until **W** shows at the upper right corner of the screen to enter the week heating mode.

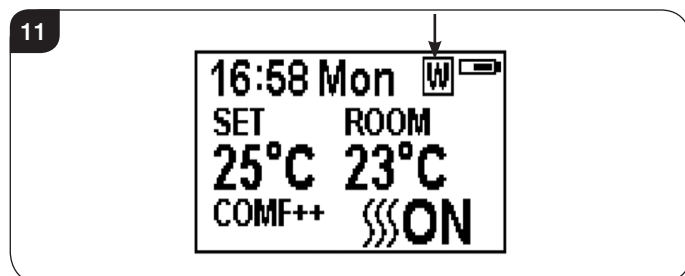

2b.30 Hold the **←** button for 6 seconds to enter the week timer heating mode setting.

2b.31 Press '**←**' or '**→**' to move the cursor (a flashing underline).

2b.32 Press the **←** button in the corresponding week position to select (the character is highlighted) or cancel (the character is displayed normally) the current setting, the same time period can be selected together.

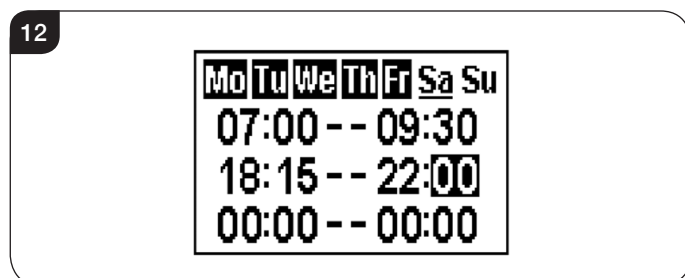

2b.33 Press the '**→**' button to move the cursor to the time period setting area.

2b.34 Press '**←**' or '**→**' button to choose hour or minute.

2b.35 Press '+' or '-' to set the number.

A maximum of 3 timed heating periods can be set per day.

Minute increment / decrement by 15min per press.

2b.36 Press **↵** to set the heating time for the selected day and return to the week line.

2b.37 Hold the **←** button for 3 seconds or wait for 10 seconds to save and exit the heating time period setting.

2b.38 Press **←** '**←**' or '**→**' to check the timer setting for the week timer heating mode.

2b.39 If the heating needs to be turned off, it will be necessary to go back to the Normal Control Mode to it turn off.

When in Weekly Timer Mode switching the appliance off with the remote will stop the light output. The heat output will continue according to the timer settings.

Adjusting the Set Temperature

2b.40 Press the '+' or '-' button to increase or decrease the temperature on the basis of COMF temperature.

COMF means the actual temperature is the same as setting.

ECO means the actual temperature is 2°C lower than the setting temperature.

ECO- means 4°C lower.

COMF+ means 2°C higher.

COMF++ means 4°C higher.

Adaptive start control

According to room temperature and set-pointed temperature, the heater will automatically determine the appropriate time to heat to ensure that it will reach the set-pointed temperature in the set time (up to 45 minutes prior to the set time).

User Instructions

Advance mode

2b.41 The heating state can be advanced to the next period is under both the daily and week timer heating mode.

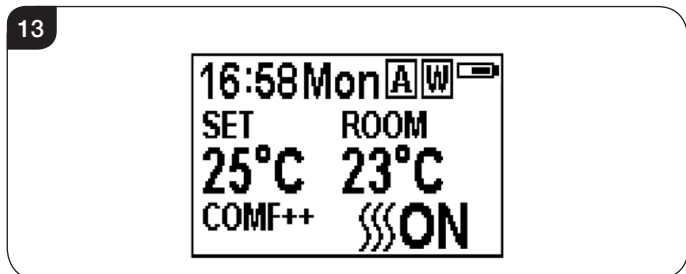

If the heater is on in the current period, pressing the button will turn the heater off.

If the heater is off in the current period, pressing the button will turn the heater on.

Whether the actual heating will be on/off also depends on the room temperature and setting temperature.

2b.42 Press **W** **A** to enter the Advance mode under the daily and week timer heating mode, **A** will show at the upper right corner of the screen.

2b.43 Press **W** **A** again or timer period ends will exit the Advance mode.

Window open detecting

2b.44 When the transmitter detects a rapid drop in room temperature, it will be judged as an open window: the warning icon will be displayed and the heating will be turned off automatically.



2b.45 After indoor temperature rise or manual intervention (by operating remote control), it will return to normal working state.

3. Maintenance

3.1 **ALWAYS UNPLUG FROM MAINS SUPPLY BEFORE CLEANING OR UNDERTAKING ANY MAINTENANCE.**

GENERAL CLEANING

3.2 Only clean the outer casing when it is cold. Do not use abrasive cleaners.

CLEANING FRONTS

3.3 Wipe the glass viewing panel with a damp cloth and buff with a lint free duster.

Caution: Do not use abrasive cleaners on the glass panel. Do not spray liquids directly onto any surface of the unit.

CLEANING THE FUEL EFFECT

To access the fuel effect it will be necessary to remove the glass viewing panel.

3.4 Ensure the appliance is unplugged.

3.5 First remove the decorative trim. The trim is held on by magnets. Pull gently forward to remove, see Diagram 15.

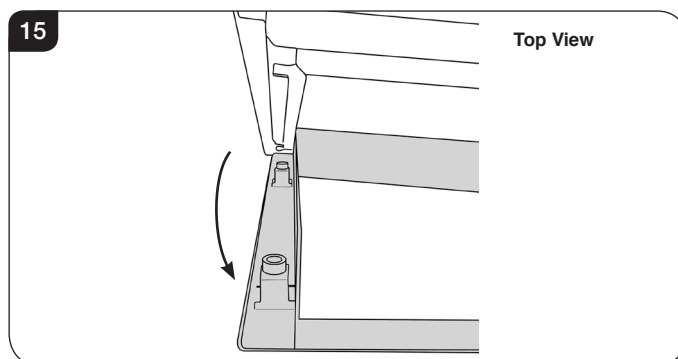

3.6 There is a clamp at the top of each corner of the glass viewing panel that secure the glass in place, see Diagram 16.

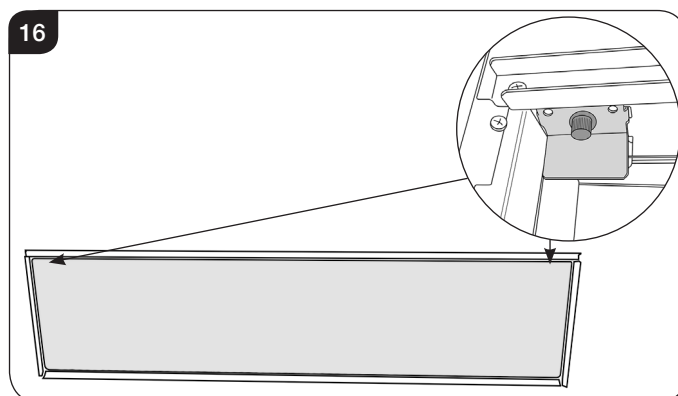

User Instructions

- 3.7 Supporting the glass, loosen and remove the 2 clamps. These can be unscrewed using just finger tips.
- 3.8 Carefully tip the glass forward and lift out of the lower tray to remove from the appliance, see Diagram 17.

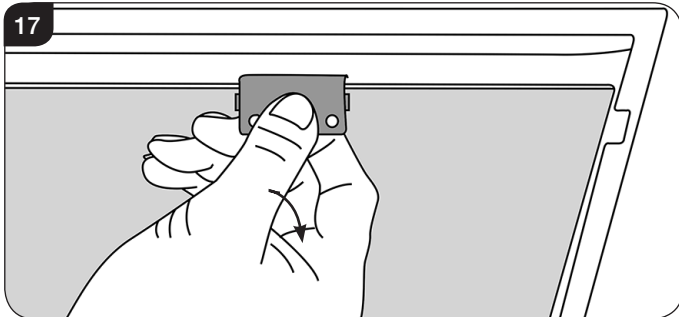

The fuel effect can now be accessed.

- 3.9 Remove and wash the fuel effect to remove any dust particles. Alternatively clean with a lint free duster. **Ensure that the effect is dry before replacing.**
Replace the fuel effect see Installation Instructions Section 5 for layout.
- 3.10 Replace the glass following the instructions in reverse order.
When replacing the clamps ensure that the tabs on the clamps locate in the slots on the appliance, see Diagram 18.

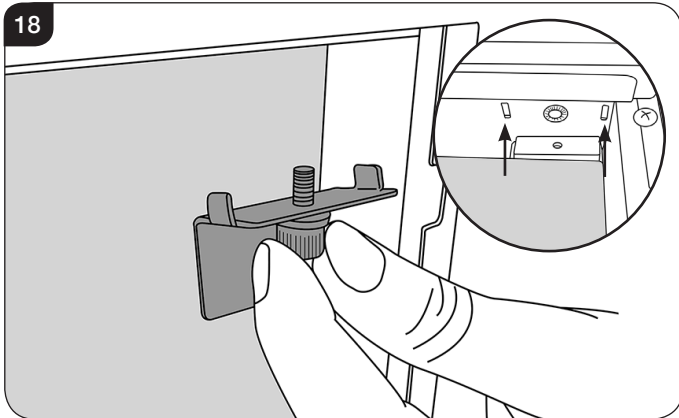

- 3.11 Replace the decorative trim.

CLEANING AIR INLETS

- 3.12 Ensure the appliance is unplugged.
- 3.13 Clean the air inlet and outlet grilles regularly with a soft cloth or the nozzle of a vacuum cleaner.

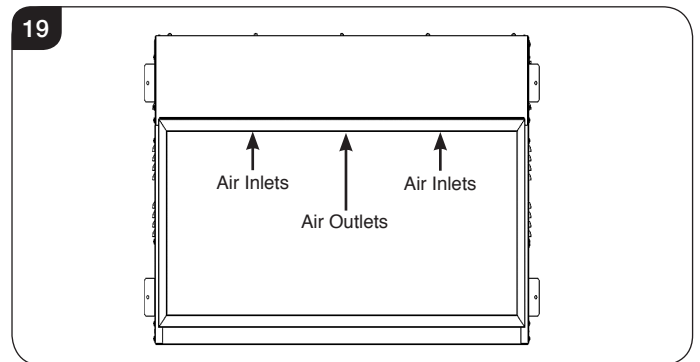

Dust build-up can inhibit efficient performance of the fan and lead to the safety cut-out operating.

- 3.14 Keep the area around the appliance clean and free of fluff, dust or pet hair.
- 3.15 In particular, build-up of dust etc. can occur around the heater area. Take particular care to keep this area free from such particles on a regular basis to prevent build-up.

BATTERY REPLACEMENT

- 3.16 When the remote battery is low it must be changed immediately. Install correct replacement and dispose of the old battery carefully at an appropriate recycling facility.

Installation Instructions

Technical Specification

These instructions cover the following models:

eReflex Inset 55R	eReflex Inset 75R	eReflex Inset 85R	eReflex Inset 105R	eReflex Inset 135R	eReflex Inset 195R
210-063AZ	210-071AZ	210-009AZ	210-017AZ	210-023AZ	210-031AZ

A 220V-240V 10A 50Hz supply is required

THIS APPLIANCE MUST BE EARTHED

Maximum power consumption:

eReflex Inset 55R: 2000 Watts

eReflex Inset 75R: 2000 Watts

eReflex Inset 85R: 2000 Watts

eReflex Inset 105R: 2000 Watts

eReflex Inset 135R: 2000 Watts

eReflex Inset 195R: 2000 Watts

A 1.8 metre lead with a plug is supplied.*

2 x Remote control handset battery (AAA)

* USE OF ALTERNATIVE POWER LEADS IS NOT RECOMMENDED AND MAY VOID WARRANTY.

If an alternative power lead is used care should be taken to ensure conductor size and connector type is suitable carrying continuous 10A load.

PACKING CHECKLIST

Appliance Description	Fixing Kit containing:
eReflex Inset 55R eReflex Inset 75R eReflex Inset 85R eReflex Inset 105R eReflex Inset 135R eReflex Inset 195R	1 x Instruction Manual 1 x Remote Control 2 x AAA Batteries 4 x Fixing Brackets 10 x Screws ST4x8 4 x Screws ST4x12 1 x Plug Bracket 1 x Power Cable Box 1 Grey Pebble Effect Clear Pebble Effect Box 2 Small Ice Effect Crystals Large Ice Effect Crystals Box 3 1 x Log Set Box 4 1 x Log Set

Note: Box numbers will vary depending on appliance model.

Control System Technical Data			
	Main Control Board	Remote Receiver Board	Remote Control
Hardware	RC01-041A01 V2	RF290B V1.2	RF290A-TX V1.3
Software	RC01-041A01 V2	-	RF290C V06.0.HEX
Frequency	-	-	ASK/OOK 433.92MHz
Maximum Transmit Power	-	-	10mW

Technical Specification

55R / 75R

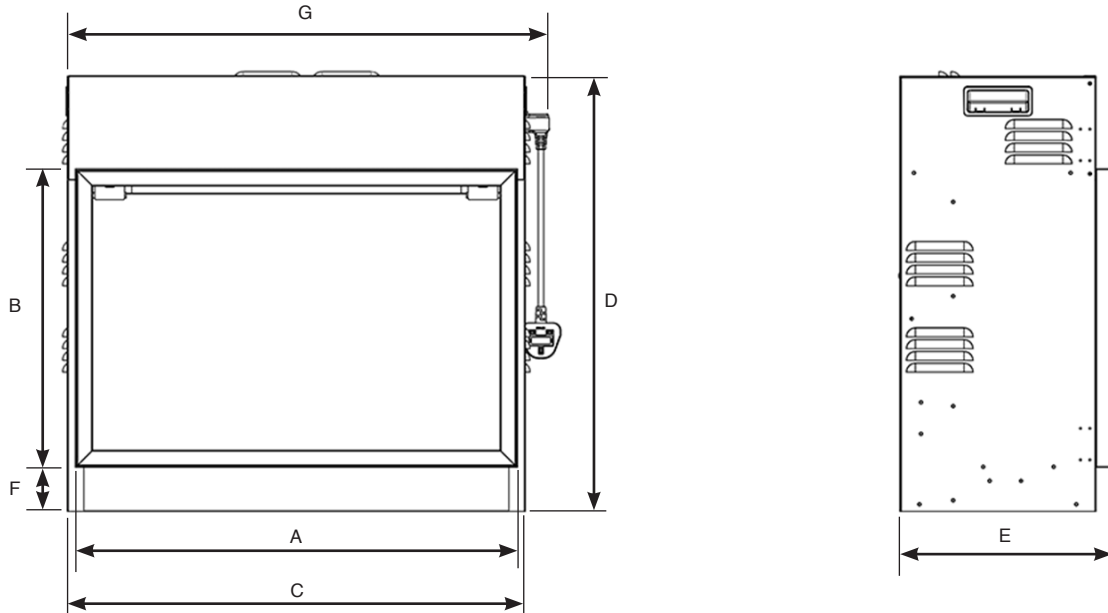

Model	A	B	C	D	E	F	G
eReflex Inset 55R	600	600	620	780	300	57	657
eReflex Inset 75R	800	800	820	980	300	57	857

85R / 105R / 135R / 195R

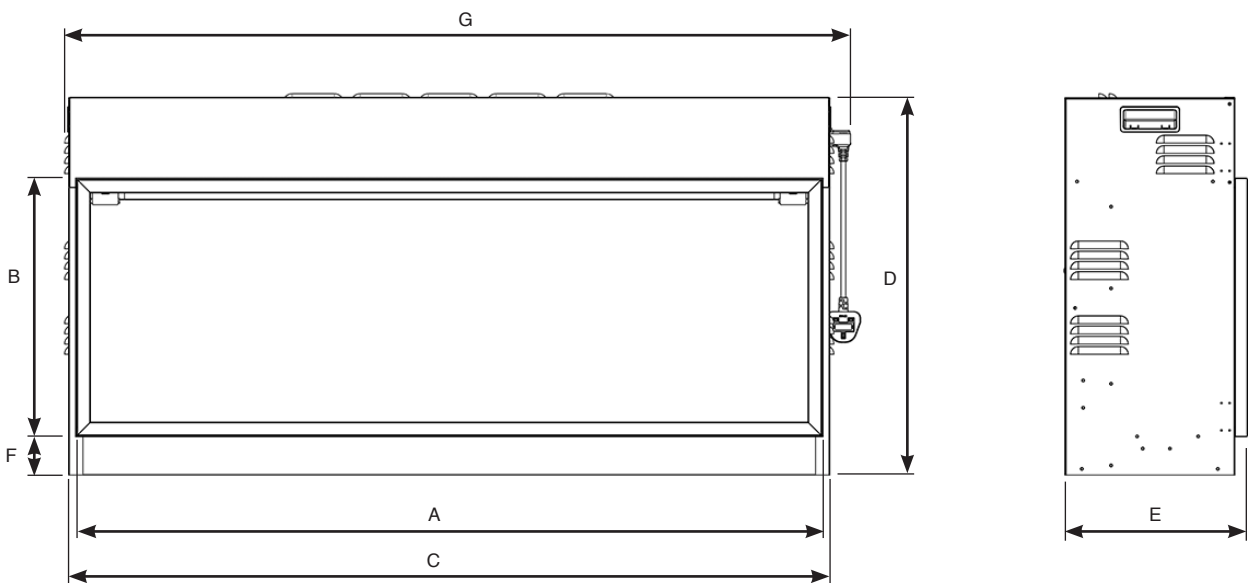

Model	A	B	C	D	E	F	G
eReflex Inset 85R	900	380	920	560	270	57	957
eReflex Inset 105R	1100	380	1120	560	270	57	1157
eReflex Inset 135R	1400	380	1420	560	270	57	1457
eReflex Inset 195R	2000	380	2020	560	270	57	2057

Installation Instructions

1. General

1.1 TOOLS REQUIRED

A Screwdriver, Spirit Level, Saw and Drill will be needed.

1.2 UNPACKING THE FIREPLACE

WARNING! DO NOT use this appliance if any part has been exposed to water.

Immediately call a suitably qualified person to inspect and to replace any part of the electrical system if necessary.

1.3 Open the packaging carefully and remove the polystyrene. Remove and discard the plastic bag. Keep plastic wrapping away from children. Be responsible when handling the packing materials.

1.4 Check all parts and accessories are removed before disposing of any packaging. If necessary keep the original packaging for future transport and/or storage.

1.5 Test the appliance before installation.

2. Fitting the Appliance

2.1 Locating the eReflex

Your new eReflex may be installed virtually anywhere in your home. However, when choosing a location ensure that the general instructions are followed.

The heater should ideally be fitted into/onto an internal flat wall constructed from either studwork and plasterboard block/brick. The fixings provided are for use on brick walls ONLY. Please ensure that suitable fixings are used when securing to any hollow or purpose built cavity.

NOTE: Should the appliance be fitted backing on to an outside wall, into a Cavity Wall, open chimney or opening that may be subject to damp and draft, it is necessary that adequate precautions are taken to avoid the appliance coming into contact with moisture or excessive drafts. In such installations, any existing chimney and/or external air vents should be fully sealed.

2.2 For best results, install out of direct sunlight.

2.3 **The appliance should be installed in a purpose built studwork enclosure. Please ensure that suitable fixings are used when securing to any hollow or cavity walls.**

2.4 **Make sure there are no pipes or cables behind the area to be drilled or cut.**

2.5 Always ensure the appliance is adequately supported and sits on a firm structure when mounting above floor level.

2.6 The appliance should ideally be located close to a suitable mains socket to enable connection. An extension could be run from an existing socket outlet but this must be carried out by a suitably qualified person. The electrical socket must be easily accessible to allow disconnection when the appliance is fitted.

- 2.7 If the power cord is damaged, it must be repaired by the manufacturer, its authorised service centre or a suitably qualified person.
- 2.8 Ensure that curtains and furniture are not positioned close to the chosen position, as this would create a potential fire hazard or block the heater outlet ducts.

WARNING! KEEP ALL COMBUSTIBLE MATERIALS AT LEAST 1M FROM THE FRONT OF THE ELECTRIC FIREPLACE.

3. Studwork Installation

3.1 Build the studwork chimney breast and enclosures to the desired size, see Diagram 1 and table.

It is essential to include a header at the required height to ensure the appliance does not support the weight of the finished wall.

It is important to allow for the finished face when setting the depth of the frame.

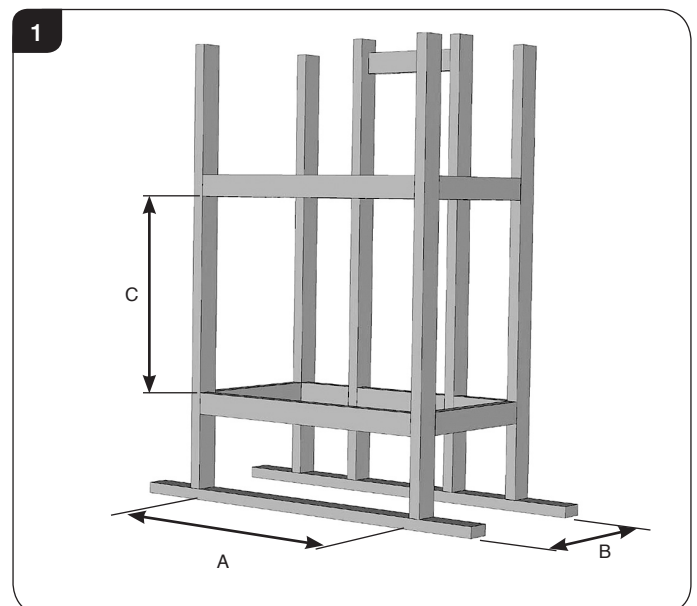

Model	Frame Minimum Width A (mm)	Frame Minimum Depth B (mm)	Frame Minimum Opening Height C (mm)
eReflex 55R	645	325	785
eReflex 75R	845	325	985
eReflex 85R	945	295	565
eReflex 105R	1145	295	565
eReflex 135R	1445	295	565
eReflex 195R	2045	295	565

Combustible or non-combustible building materials may be used to finish up to the appliance casing. The product is a zero clearance design. Ensure that the stud or any materials used to seal the cavity (if required) do not obstruct the air vents on the top and sides of the appliance.

Installation Instructions

i NOTE: 2 sets of holes have been provided depending on the thickness of the plasterboard to be used for the desired finish, see Diagram 2.

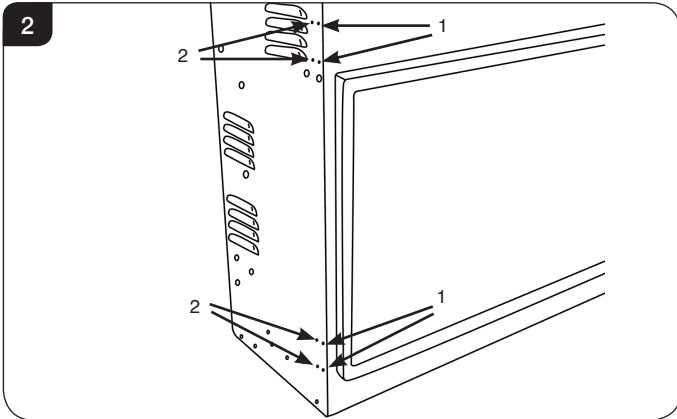

3.2 Attach the 4 fixing brackets to the sides of the appliance, see Diagram 3.

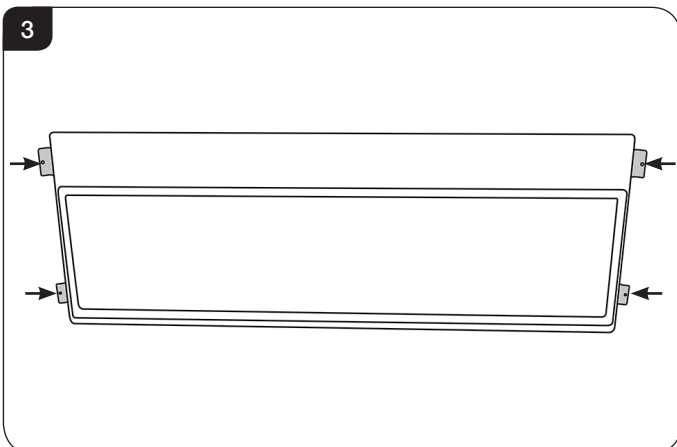

3.3 The fireplace can now be positioned in the opening. Level the appliance, and attach the unit to the frame using the fixing holes provided, see Diagram 4.

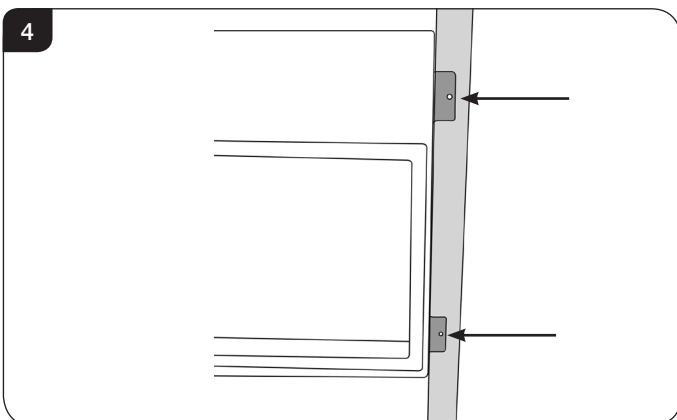

3.4 Connect the power cable to the appliance.

3.5 A securing bracket has been supplied. Place the bracket around the plug and secure with 2 screws, see Diagram 5.

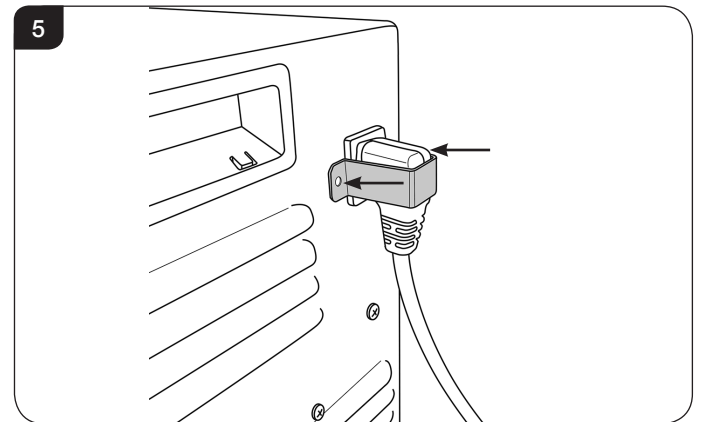

3.6 The decorative trim is held on by magnets. Pull gently forward to remove, see Diagram 6.

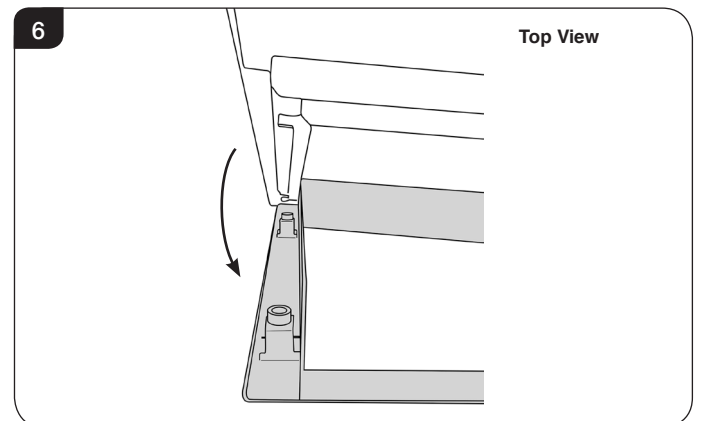

3.7 **Combustible or non-combustible building materials** may be used to finish up to the fireplace opening.

DO NOT PACK THE VOID AROUND OR ABOVE THE APPLIANCE WITH INSULATION MATERIALS SUCH AS MINERAL WOOL.

3.8 There is a return surrounding the decorative trim attached to the front of the appliance. This allows suitable boarding to be taken up to the edge and finished off with an even 5mm gap around of the decorative trim, see Diagram 7.

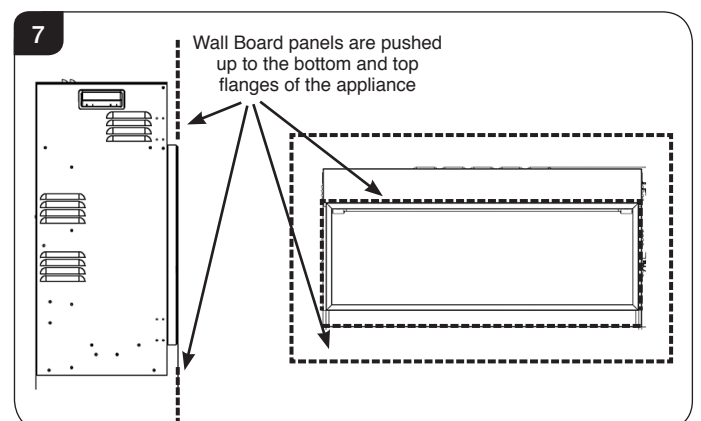

Installation Instructions

3.9 With the decorative trim removed, fit suitable boarding to the wall above, below and to the sides of the appliance.

Combustible or non-combustible building materials may be used to finish up to the fireplace opening (glass viewing area). DO NOT PACK THE VOID AROUND OR ABOVE THE APPLIANCE WITH INSULATION MATERIALS SUCH AS MINERAL WOOL.

3.10 Finish the chimney breast as desired.

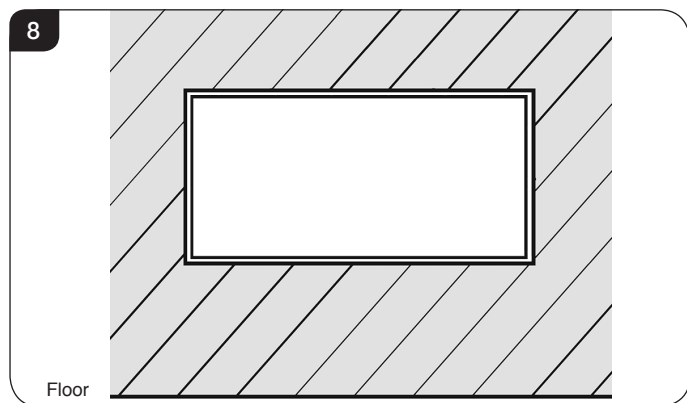

4. Removing the Exterior Glass

4.1 To place the fuel effect it will be necessary to remove the exterior glass panel.

4.2 First remove the decorative trim. The trim is held on by magnets. Pull gently forward to remove, see Diagram 9.

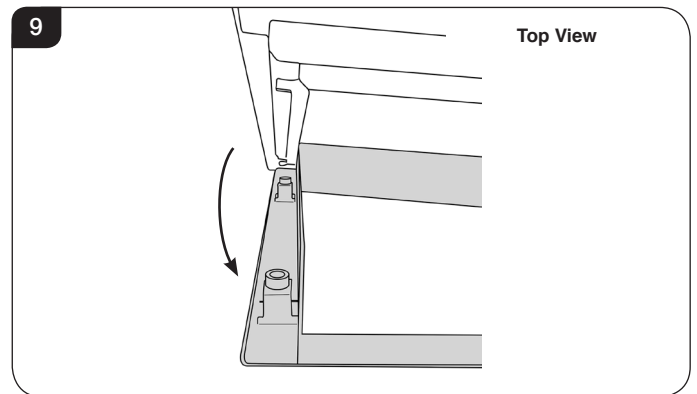

4.3 There is a clamp at the top of each corner of the glass viewing panel that secure the glass in place, see Diagram 10. **Take care to support the glass when removing clamps.**

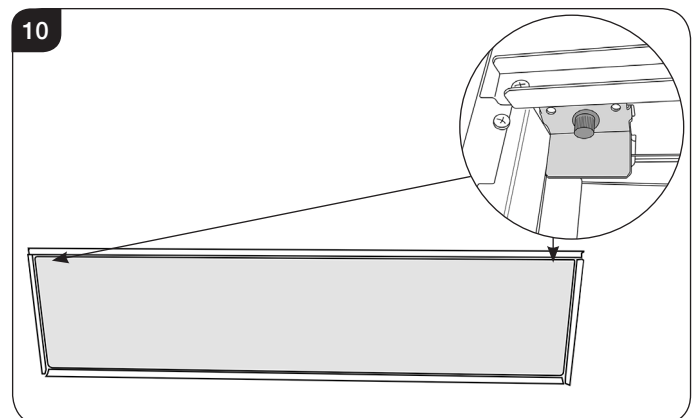

4.4 Supporting the glass, loosen and remove the 2 clamps. These can be unscrewed using just finger tips.

4.5 Carefully tip the glass forward and lift out of the lower tray to remove from the appliance, see Diagram 11. The clamp can be used to aid removal.

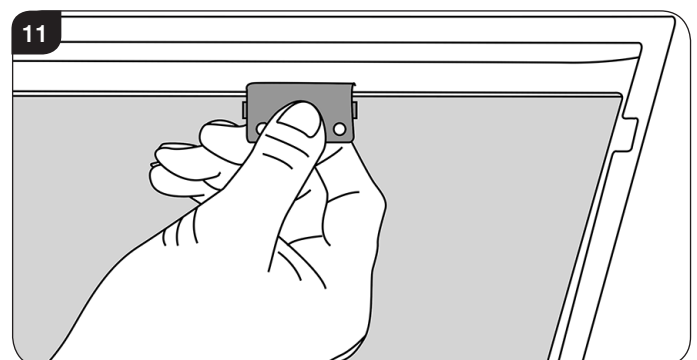

5. Fuel Effect

5.1 The appliance is supplied with 2 fuel effect options:

5a. Log Effect.

5b. Crystal Ice Effect.

5a. Log Effect

LOGS MUST BE POSITIONED ACCORDING TO THE FOLLOWING INSTRUCTIONS TO GIVE THE CORRECT FLAME EFFECT.

The logs for the fuel bed are NOT individually labelled, the numbers are for reference information only.

5a.1 Evenly spread the clear pebble effect across the fuel bed.

5a.2 Randomly space the grey pebble effect throughout the fuel bed.

5a.3 Identify the logs using Diagram 12 and the table below.

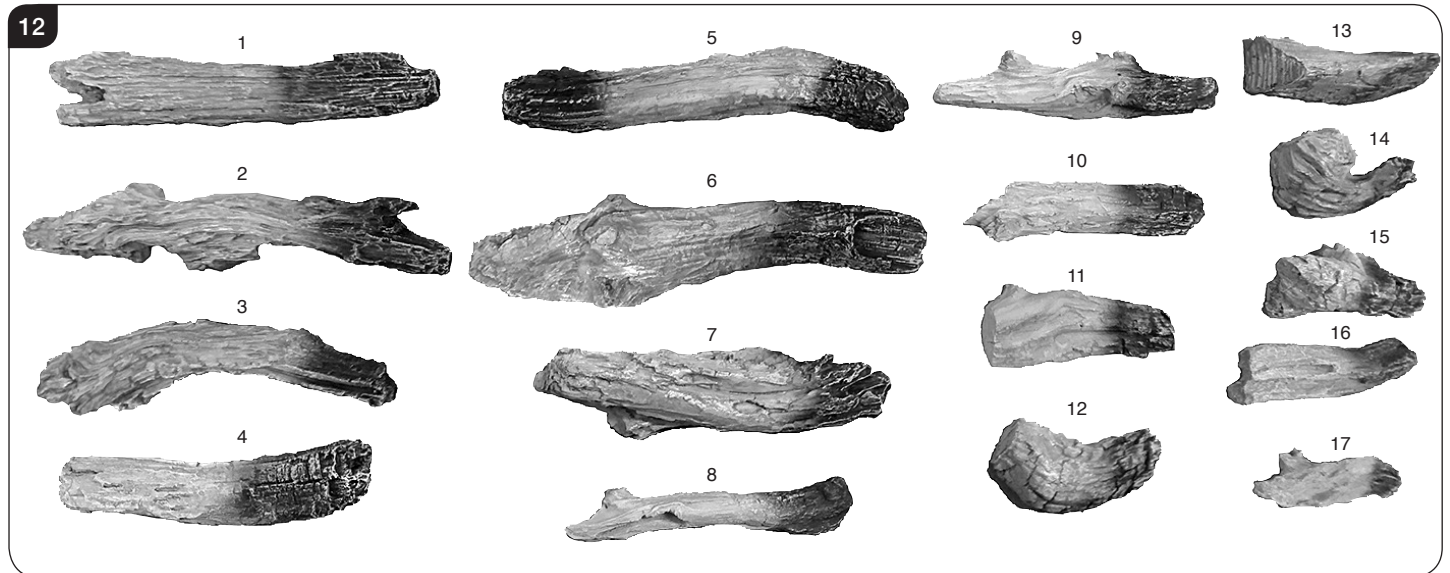

	Log Size	eReflex Inset 55R	eReflex Inset 75R	eReflex Inset 85R	eReflex Inset 105R	eReflex Inset 135R	eReflex Inset 195R
1	Large						✓
2	Large			✓	✓	✓	✓
3	Large						✓
4	Large						✓
5	Large					✓	✓
6	Large	✓	✓	✓	✓	✓	✓
7	Large	✓	✓	✓	✓	✓	✓
8	Medium		✓	✓	✓	✓	✓
9	Medium	✓	✓		✓	✓	✓
10	Medium	✓	✓		✓	✓	✓
11	Small						✓
12	Small					✓	✓
13	Small	✓	✓	✓	✓	✓	✓
14	Small			✓	✓	✓	✓
15	Small						✓
16	Small					✓	✓
17	Small			✓	✓	✓	✓
	Total	1 Small 2 Medium 2 Large	1 Small 3 Medium 2 Large	3 Small 1 Medium 3 Large	3 Small 3 Medium 3 Large	5 Small 3 Medium 4 Large	7 Small 3 Medium 7 Large

Installation Instructions

55R/ 75R Layout

Please refer to Diagram 12 and table on page 15 to identify the logs for specific models.

5a.4 The logs are positioned in groups. Working from left to right, place the logs onto the stone fuel effect following the layouts below:

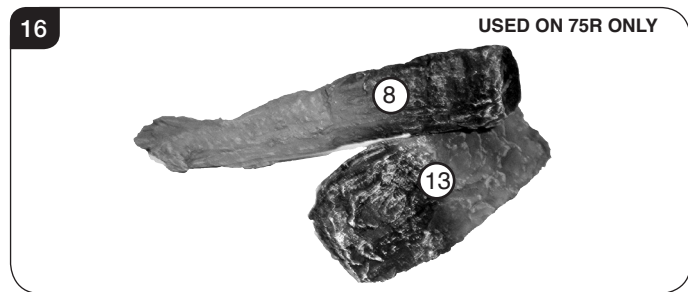
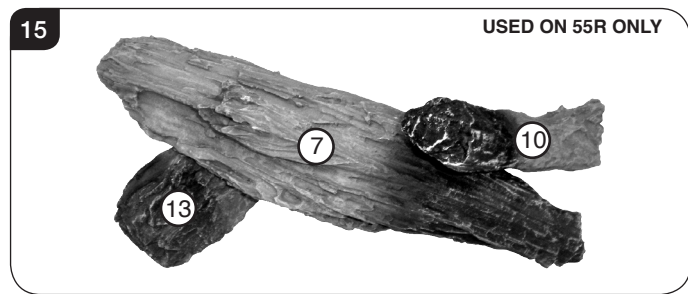
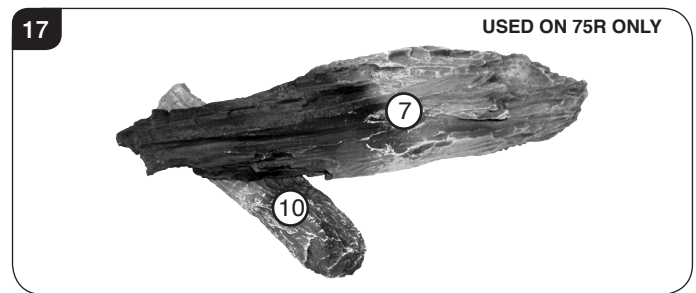
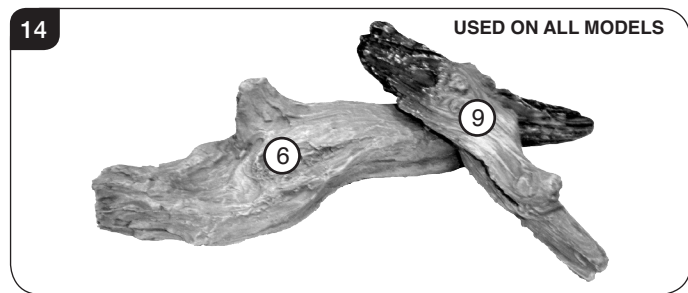
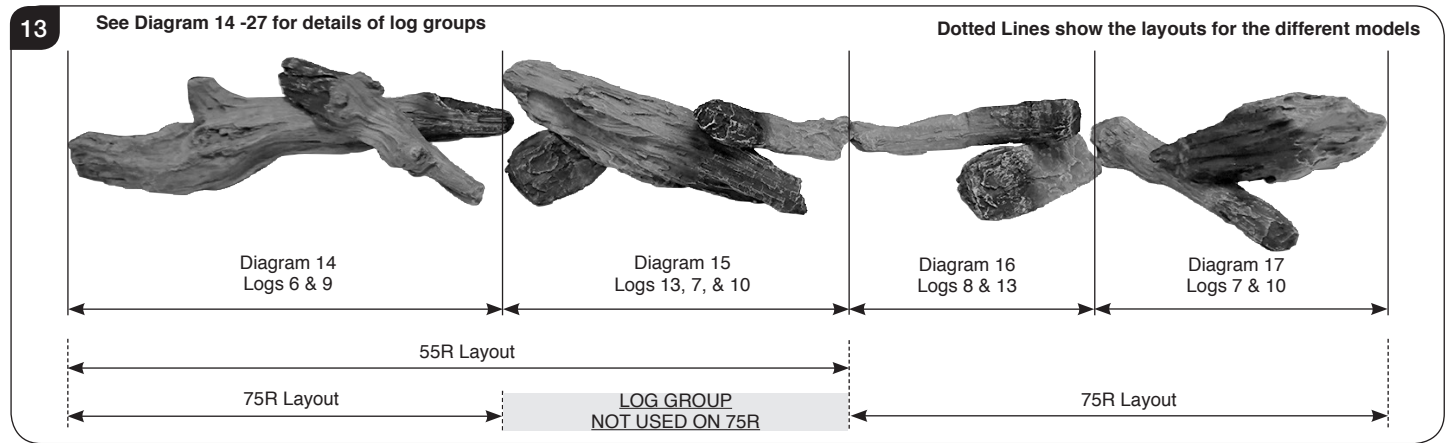

5a.5 If desired the Crystal Ice Effect can be placed in between the log layout, see Section 5b.

85R/ 105R/ 135R/ 195R Layout

Please refer to Diagram 12 and table on page 15 to identify the logs for specific models.

5a.6 The logs are positioned in pairs. Working from left to right, place the logs onto the stone fuel effect following the layouts below:

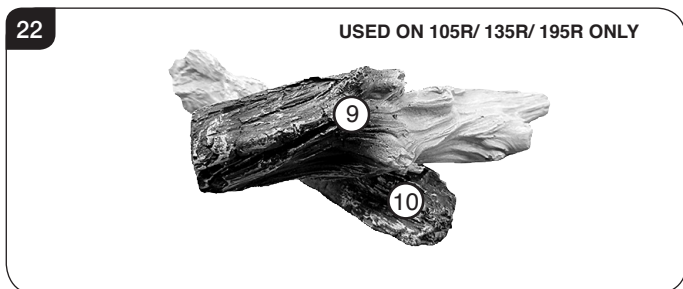
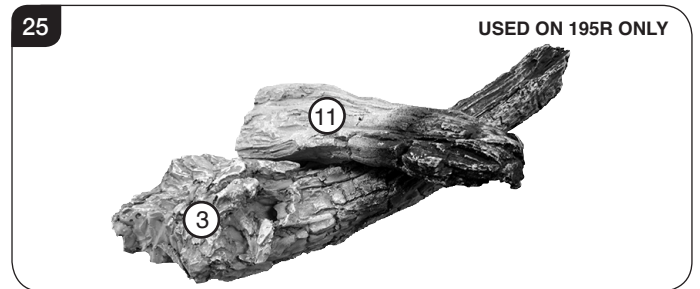
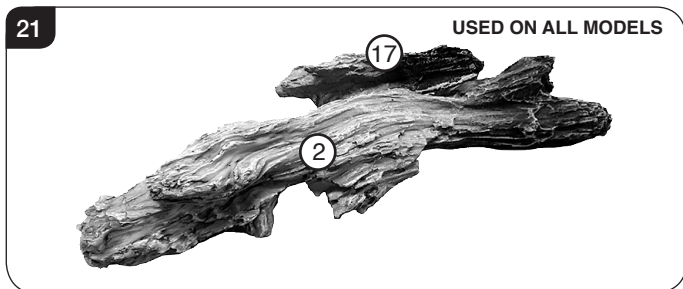
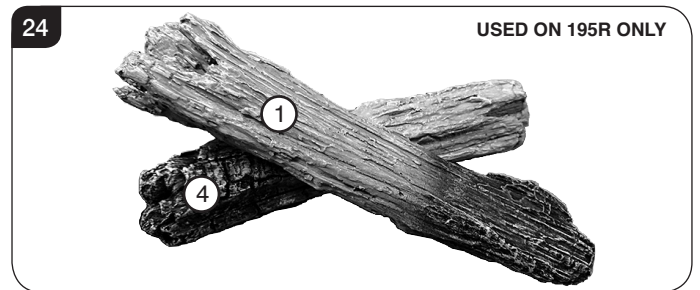
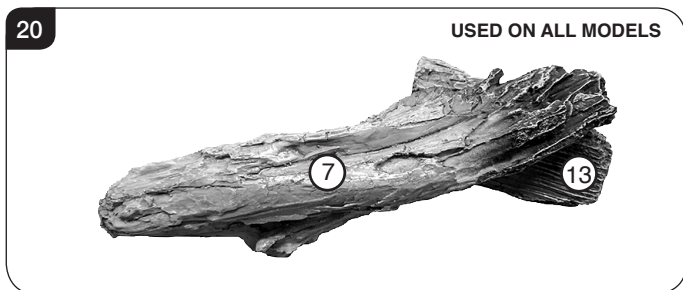
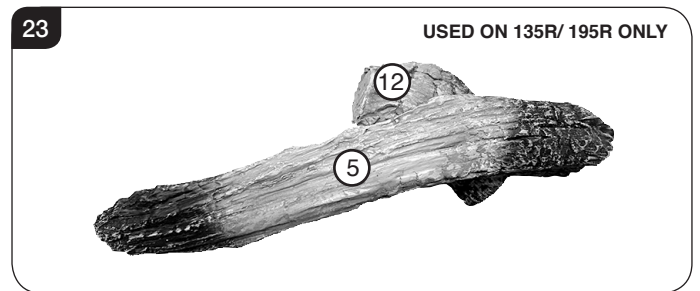
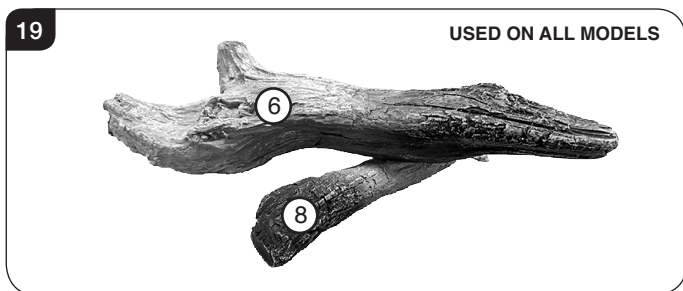
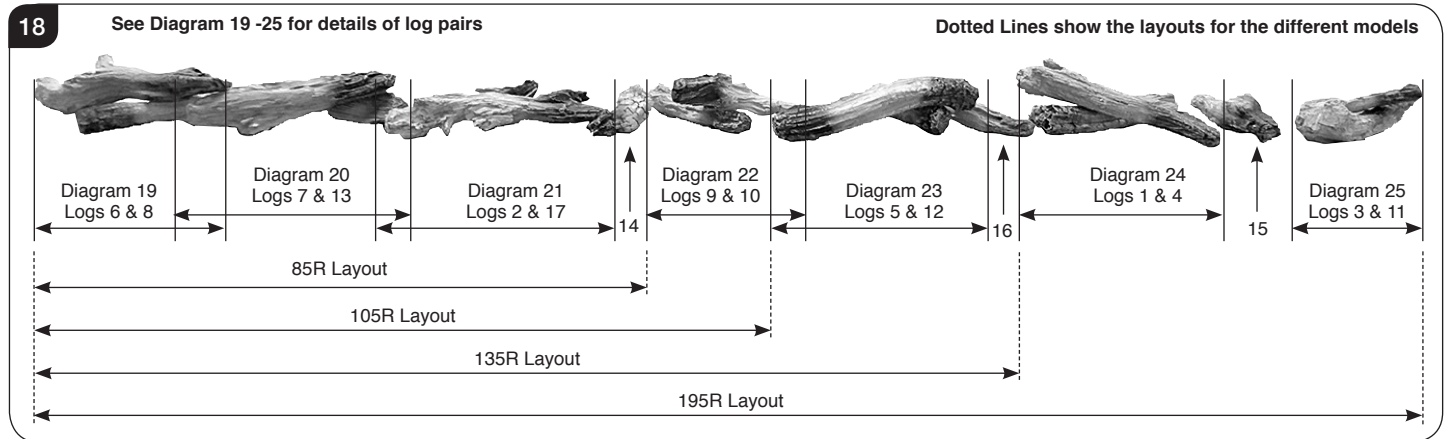

5a.7 If desired the Crystal Ice Effect can be placed in between the log layout, see Section 5b.

Installation Instructions

5b. Crystal Ice Effect

5b.1 Evenly spread the small Ice effect crystals across the fuel bed.

It is not necessary to use all of the effect supplied.

5b.2 Randomly space the large Ice effect crystals throughout the fuel bed.

6. Completion of Assembly

6.1 Replace the glass following the instructions in reverse order.

IMPORTANT: When replacing the glass the black tabs must be positioned at the top corners of the appliance.

When replacing the clamps ensure that the tabs on the clamps locate in the slots on the appliance, see Diagram 26.

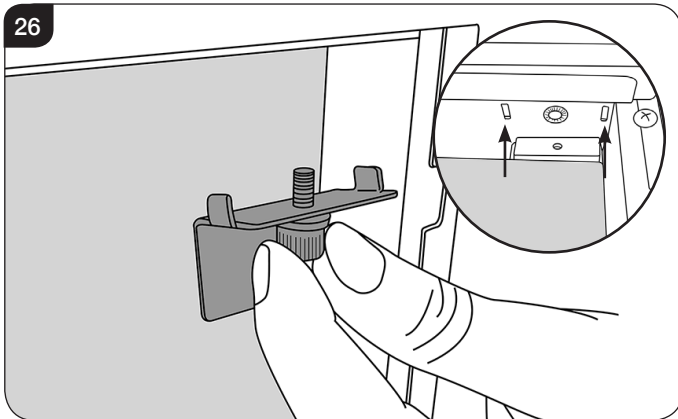

6.2 Replace the decorative trim to finish the installation.

Servicing Instructions

1. Fault Finding

No illumination or uneven lighting:

- 1.1 First change the fuse for one known to work. If the appliance still does not work, check the socket by plugging in a working appliance. If this too fails to operate, call in a competent electrician to check the socket.
- 1.2 One or more of the LED boards will need replacing. This must be undertaken by a suitably qualified person (see *Servicing Requirements*).

Illumination but no heat:

- 1.3 The safety cut-out has operated to protect against overheating (see *User Instructions, Section 2*). Ensure the air inlet and outlet grilles are free of dust or any other obstruction.
- 1.4 The thermostat control may be set too low. Increase the setting by pressing the thermostat button on the remote control until the heater turns on.

Remote control fails to work:

- 1.5 Check that the batteries are new and correctly fitted. Replace if necessary.
- 1.6 Ensure that the handset is pointed towards the fire.

2. Servicing Requirements



DURING SERVICING OF THIS APPLIANCE IT MAY BE NECESSARY TO CUT CABLE TIES IN ORDER TO ACCESS AND REMOVE SOME OF THE PARTS. THESE MUST BE REPLACED WHEN REASSEMBLING THE APPLIANCE.



WARNING: The Effects Spindles are sharp, please use caution when servicing this appliance.



NOTE: Due to the number of models covered within this instruction manual the number of screws that need to be removed during servicing may vary.

THIS APPLIANCE MUST ONLY BE SERVICED BY A SUITABLY QUALIFIED PERSON.

BEFORE UNDERTAKING ANY WORK ON THE APPLIANCE: SWITCH OFF THE APPLIANCE AND ISOLATE THE POWER SUPPLY ENSURING THERE IS NO POWER TO THE APPLIANCE.

- 2.1 Wait for at least 10 minutes until the appliance has cooled down.

2.2 Remote Handset Battery Replacement

Replace with 2 AAA batteries. Make sure the batteries are installed correctly in the remote control.

2.3 Maintenance of Motors

The motor used on the flame effect is pre-lubricated for extended bearing life and requires no further lubrication. However, periodic cleaning/vacuuming of the heater unit is recommended.

2.4 Resetting the Thermal Cutout Switch

The appliance is fitted with an Electronic Safety Control (E.S.). This is a safety device which switches off the fire if, the appliance overheats for any reason e.g. when covered.

If the heater stops operating whilst the flame effect continues normally, this indicates that the E.S. Control is in operation.

The E.S. Control can only be re-set after the appliance has cooled down.

To re-set the E.S:

Switch off the appliance (Manual On/Off switch) and leave for approximately 120 minutes.

Remove any obstruction to the fan heater outlet or other internal parts.

Switch on appliance and the E.S. Control will re-set. Ensure that the appliance is functioning correctly. If the E.S. Control operates again, the appliance should be checked by a suitably qualified person.

3. Removing the Exterior Glass

- 3.1 To access the internal working parts of the eReflex it will be necessary to remove the glass viewing panel.
- 3.2 Isolate the power supply and ensure there is no power to the appliance.
- 3.3 First remove the decorative trim. The trim is held on by magnets. Pull gently forward to remove, see Diagram 1.

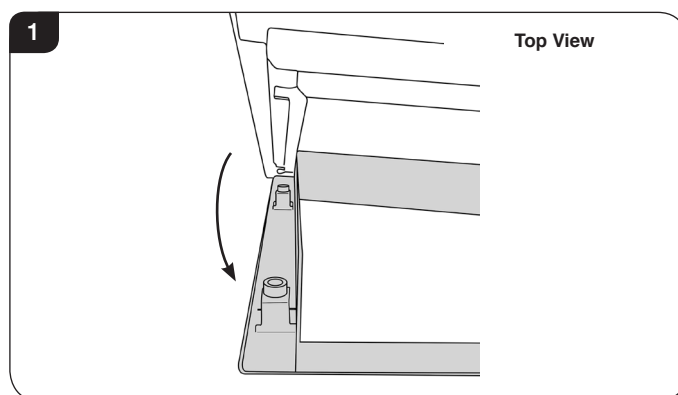

Servicing Instructions

3.4 There is a clamp at the top of each corner of the glass viewing panel that secure the glass in place, see Diagram 2.

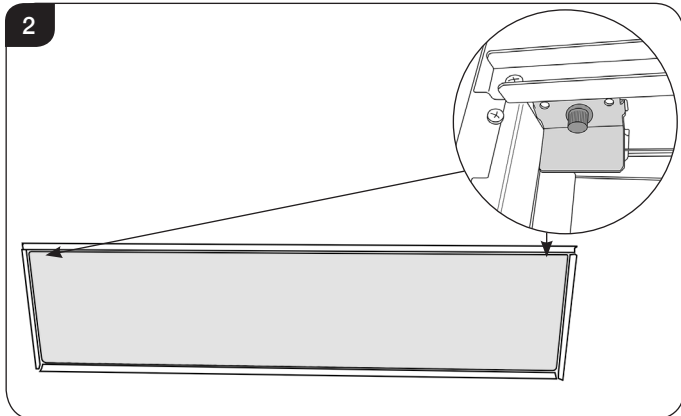

3.5 Supporting the glass, loosen and remove the 2 clamps. These can be unscrewed using just finger tips.

3.6 Carefully tip the glass forward and lift out of the lower tray to remove from the appliance, see Diagram 3. The clamp can be used to aid removal.

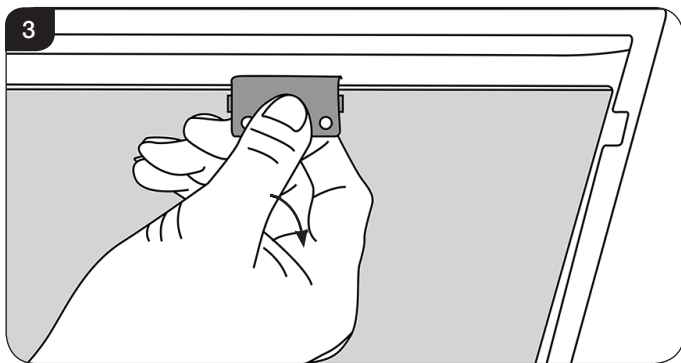

3.7 Carefully place the glass to one side to avoid damage.

3.8 Replace the glass following the instructions in reverse order.

IMPORTANT: When replacing the glass the black tabs must be positioned at the top corners of the appliance.

When replacing the clamps ensure that the tabs on the clamps locate in the slots on the appliance, see Diagram 4.

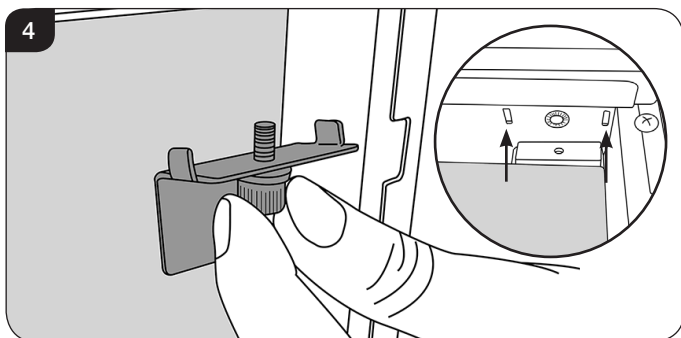

3.9 Replace the decorative trim.

4. Removing the LED Light Bar

It will be necessary to remove the LED Light Bar in order to remove the side panels, Interior Glass and to service the Power Unit.

4.1 Supporting the LED Light Bar remove the 2 end screws then the central screw(s), see Diagram 5.

Note: There is more than one central screw on larger models.

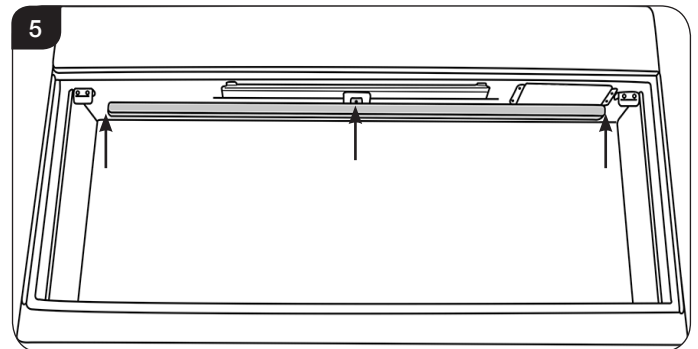

4.2 Carefully lower the LED Light Bar and disconnect the cable from the right hand side, see Diagram 6.

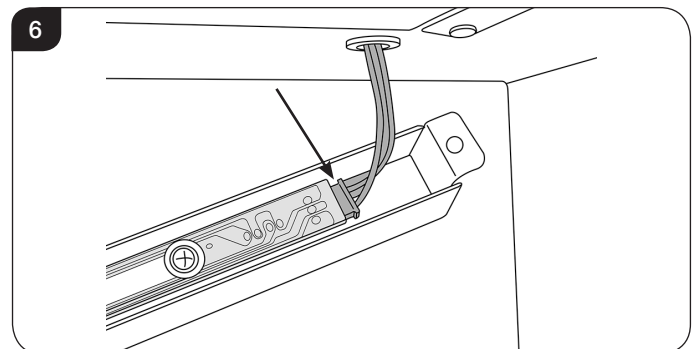

NOTE: When replacing the LED Light Bar ensure that the central tab is positioned at the front of the firebox.

5. Removing the Glass Side Panels

5.1 Follow Sections 3, & 4 to access the Interior Glass Panels.

To remove the Interior Glass it will necessary to remove the side panels:

5.2 Remove the 6 screws from the front face of the appliance, see Diagram 7.

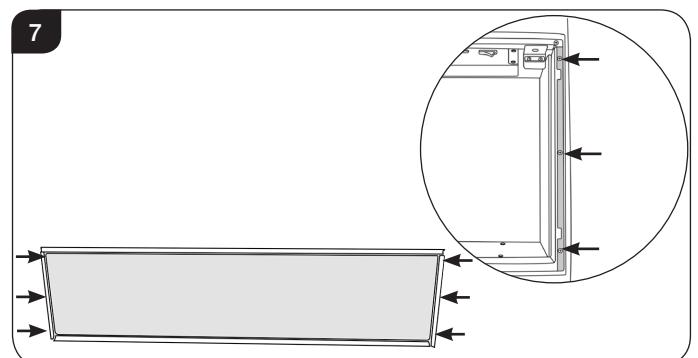

Servicing Instructions

- 5.3 Pull the side trims forward to remove.
- 5.4 Remove the 2 screws to remove the left hand top bracket, see Diagram 8.

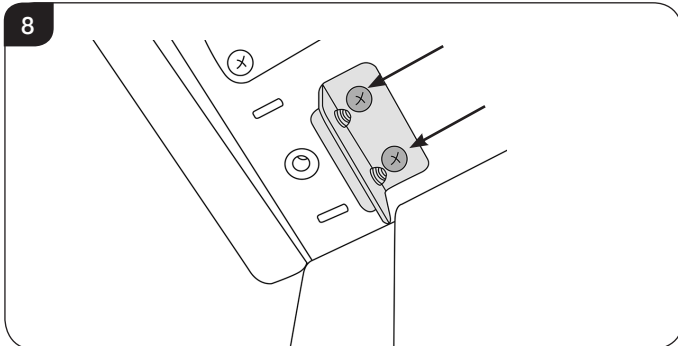

- 5.5 Carefully ease the bottom rear edge of the side panel inwards to loosen the panel.
- 5.6 Carefully pull the side brackets down at an angle and lift to remove, see Diagram 9.

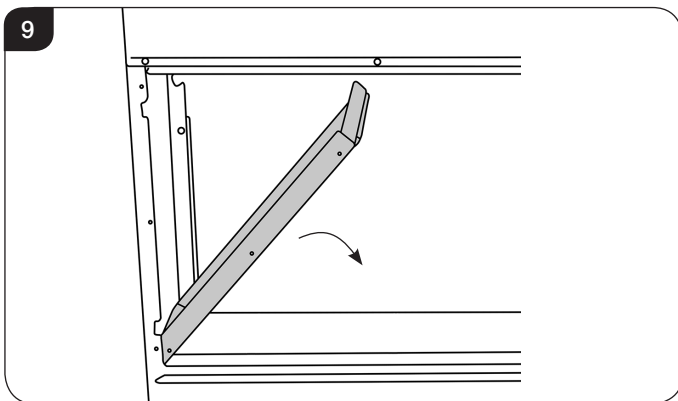

- 5.7 Repeat on the other side.

Note: When replacing the right hand panel ensure the cable is not trapped.



6. Removing the Fuel Bed

- 6.1 Follow Sections 3, 4 & 5 to access the fuel bed.

With the exterior glass removed carefully gather up the fuel effect and place to one side.

To replace the fuel effect see Installation Instructions Section 5 for layout.

- 6.2 Remove the screws from the fuel bed, see Diagram 10.

The number of screws may vary between models.

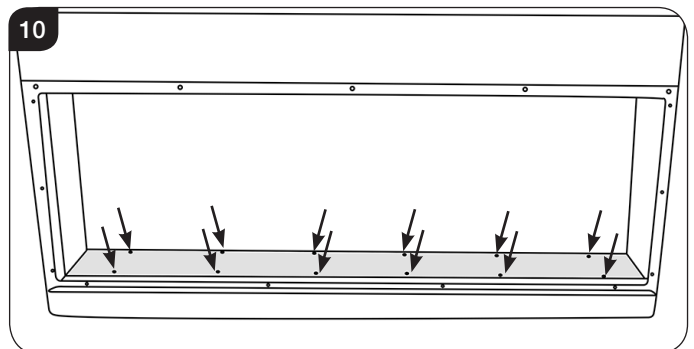

- 6.3 Hook the edge of the fuel bed at one end with a finger or screwdriver. Gently push down so that the fuel bed lifts in the middle, see Diagram 11.

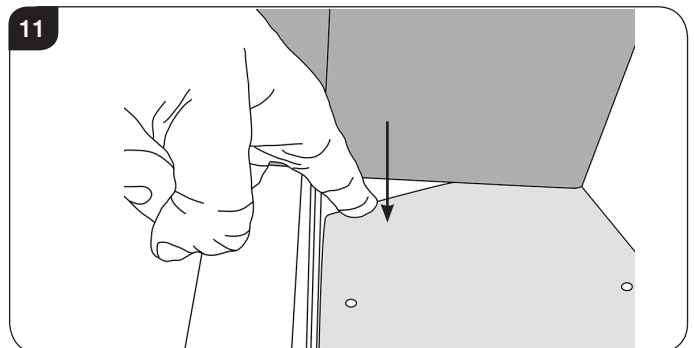

- 6.4 The flexible fuel bed can now be lifted out of the appliance.
- 6.5 When replacing the fuel bed carefully feed the ends under the side panels, see Diagram 12 (1).

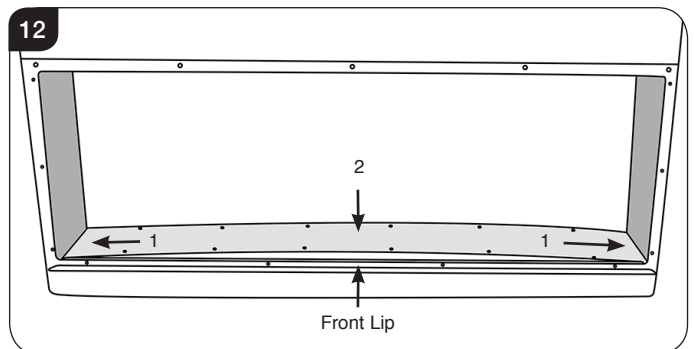

Servicing Instructions

- 6.6 Press the fuel bed flat so that the front locates under the front lip, see Diagram 12 (2). Adjust the position so that the screw holes line up.

Note: When replacing the fuel bed ensure that the rough side faces up.

7. Replacing the Fuel Bed Effects Spindle



WARNING: The Effects Spindles are sharp, please use caution when servicing this appliance.

- 7.1 Follow Sections 3, 5 & 6 to access the Fuel Bed Effects Spindle.
- 7.2 The Fuel Bed Effects Spindle is attached to the Fuel Bed Effects Motor and supported in 2 additional places (55R models only have 1 additional support), see Diagram 13.

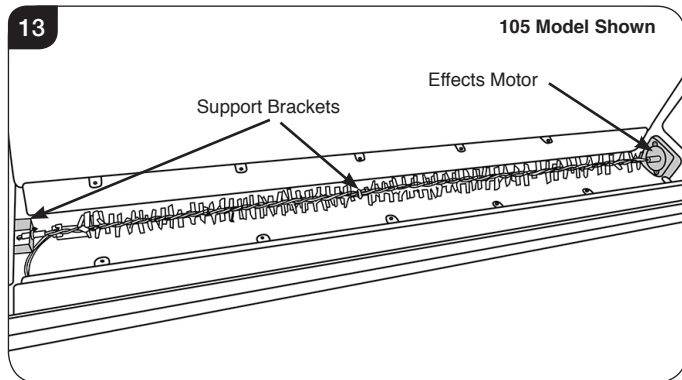

75R/ 85R/ 105R/ 135R/ 195R ONLY:

- 7.3 Remove the screw securing the Effects Spindle to the central bracket(s), see Diagram 14.

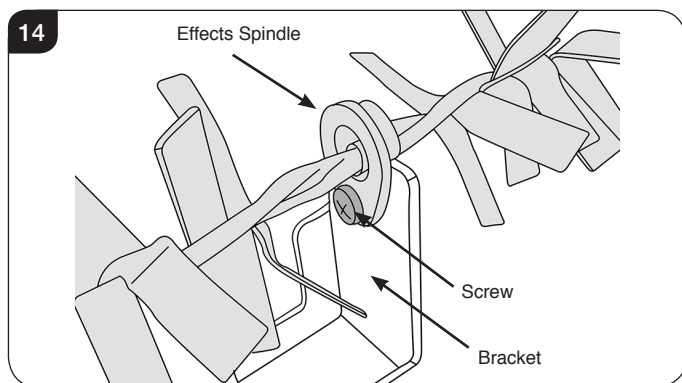

ALL MODELS:

- 7.4 The Effects Spindle is attached to the Effects Motor by a rubber sleeve. Pull the rubber sleeve off the Effect Motor axle, see Diagram 15.

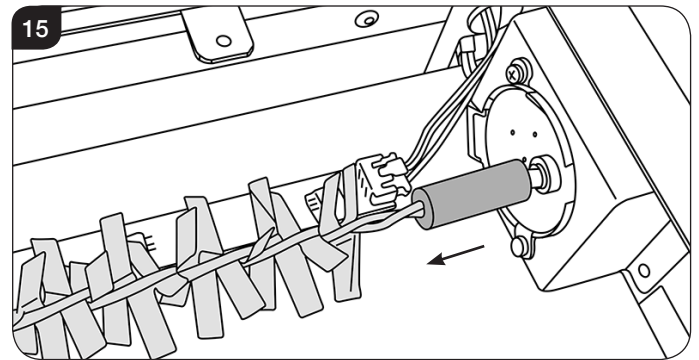

- 7.5 Withdraw the spindle from the left hand bracket, see Diagram 16. The spindle may need to be tilted to be removed from the location bracket.

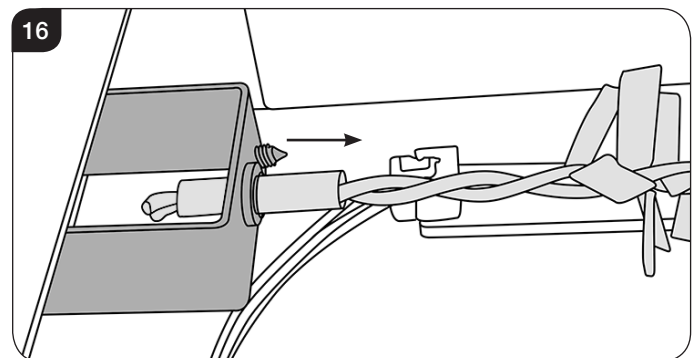

- 7.6 Replace in reverse order.

8. Replacing the Fuel Bed LED Boards

To remove the LED Boards it is NOT necessary to remove the Effects Spindle.

- 8.1 Follow Sections 4, 5 & 6 to access the Fuel Bed LED Boards.
- 8.2 The LED boards are located at the bottom of the appliance, see Diagram 17.

The number of LED Boards may vary between models.

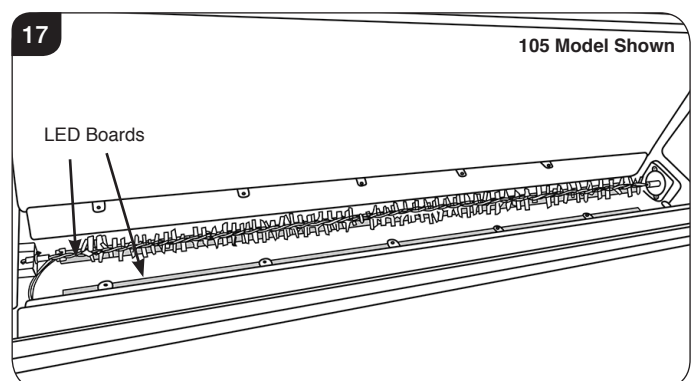

Servicing Instructions

8.3 The LED boards are coupled together at the end of each board and held in place by clips, see Diagram 18.

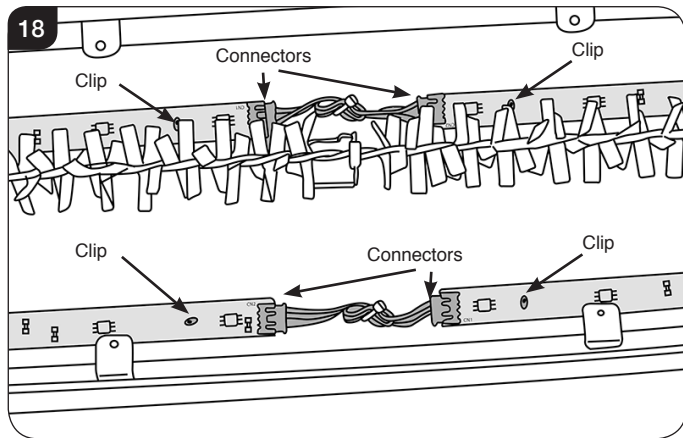

8.4 Unplug the correct LED board and use a pair of long nosed pliers to squeeze the clips and release.

8.5 Fitting a new board is the reverse of this process.

IMPORTANT: Test the LEDs before refitting the Fuel Bed.

The LED Boards must be connected correctly with the CN1 in and the CN2 out in the correct orientation, see Diagram 19.

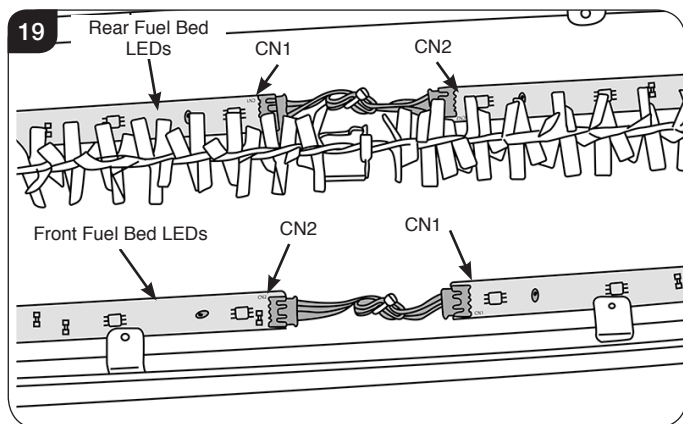

9. Removing the Interior Glass Screen

9.1 Follow Sections 3, 4 & 7 to access the Interior Glass Screen.

9.2 Remove the 4 screws to remove the glass brackets, see Diagram 20.

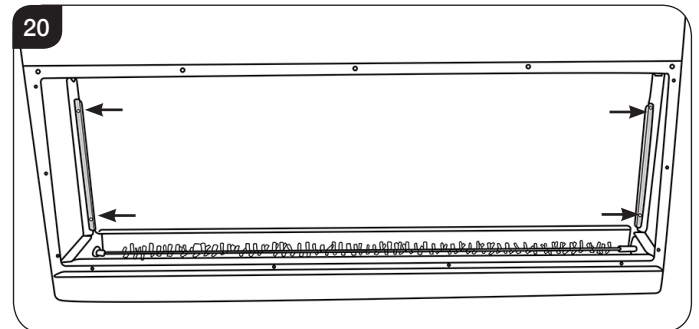

9.3 Carefully tilt the glass forward and lift to remove from the appliance, see Diagram 21.

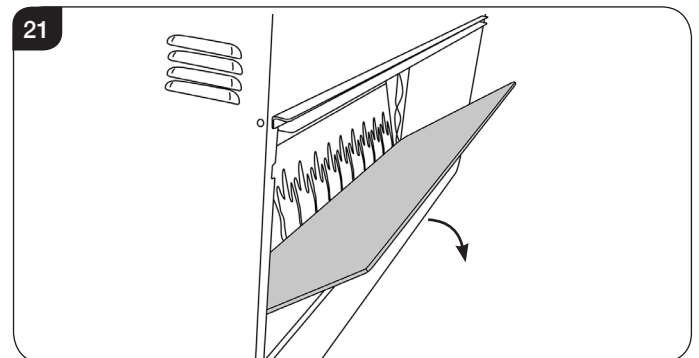

9.4 Carefully place the glass to one side to avoid damage. 2 persons will be required on 135R and 195R models due to the size and weight of the glass panel.

9.5 Replace in reverse order.

IMPORTANT: When replacing the glass the side with the glossy finish must face towards the front of the appliance.

Servicing Instructions

10. Removing the Effects Screen

- 10.1 Follow Sections 3, 4, 5, 6, 8 & 9 to access the Effects Screen.
- 10.2 Remove the 4 screws to remove the 2 side brackets, see Diagram 22.

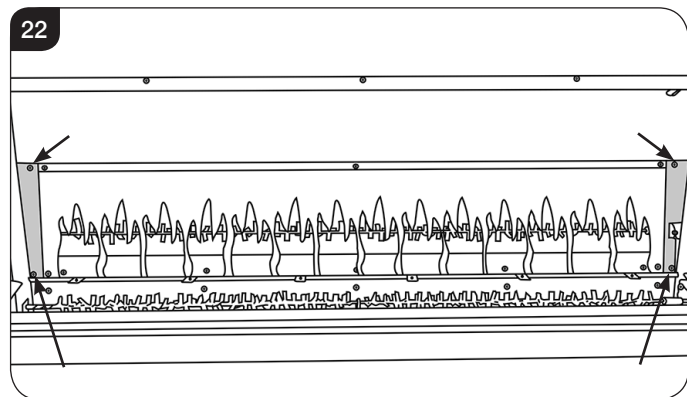

Note: When refitting the brackets the folded tab must be located at the top, see Diagram 23.

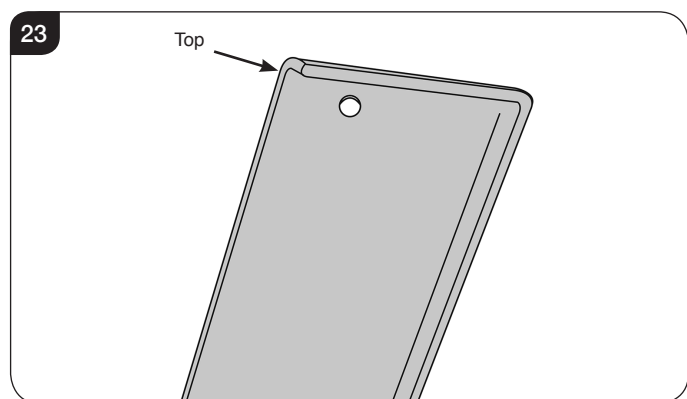

- 10.3 Remove the screws securing the top bracket, see Diagram 24 A. The number of screws may vary depending on model.

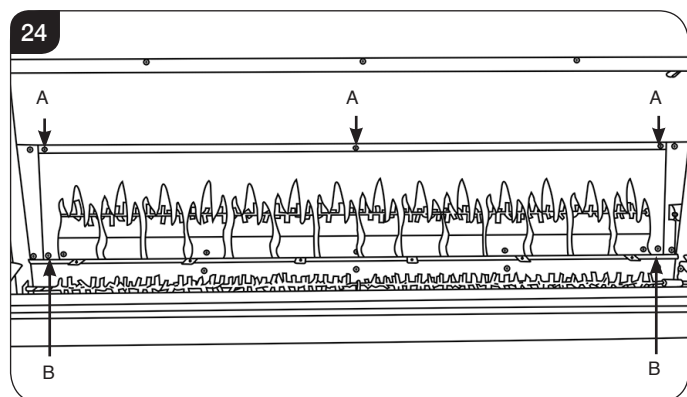

- 10.4 Supporting the Effects Screen remove the 2 screws from the bottom corners of the screen, see Diagram 24 B.
- 10.5 Replace in reverse order.

IMPORTANT: When replacing the Effects Screen the side with the glossy finish must face towards the front of the appliance with the flames in the correct orientation.

11. Replacing the Flame Effects Spindle



WARNING: The Effects Spindles are sharp, please use caution when servicing this appliance.

- 11.1 Follow Sections 3, 4, 5, 6, 8, 9 & 10 to access the Flame Effects Spindle.
- 11.2 The Flame Effects Spindle is attached to the Flame Effects Motor and supported in 2 additional places (55R models only have 1 additional support), see Diagram 25.

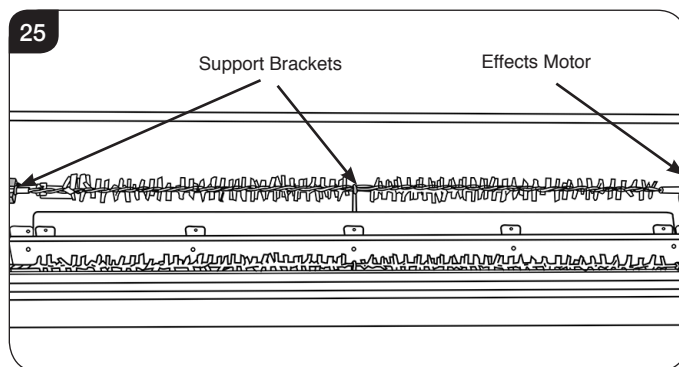

75R/ 85R/ 105R/ 135R/ 195R ONLY:

- 11.3 Remove the screw securing the Effects Spindle to the central bracket, see Diagram 6.

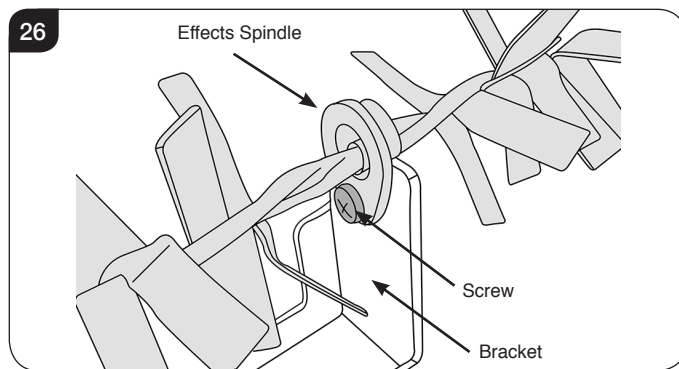

ALL MODELS:

- 11.4 The Effects Spindle is attached to the Effects Motor by a rubber sleeve. Pull the rubber sleeve off the Effect Motor axle, see Diagram 27.

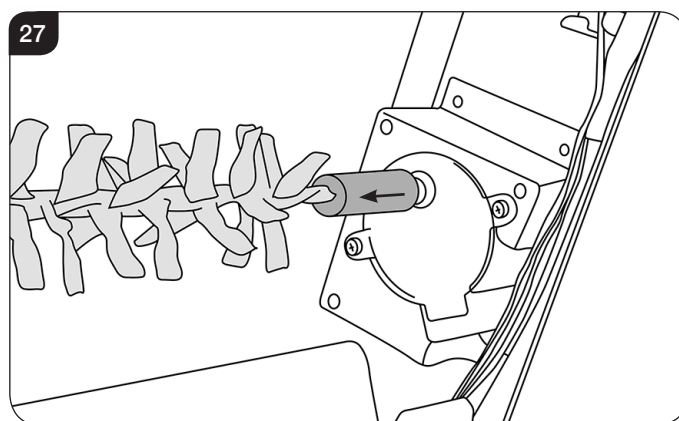

Servicing Instructions

- 11.5 Withdraw the spindle from the left hand bracket, see Diagram 28.
The spindle may need to be tilted to be removed from the location bracket.

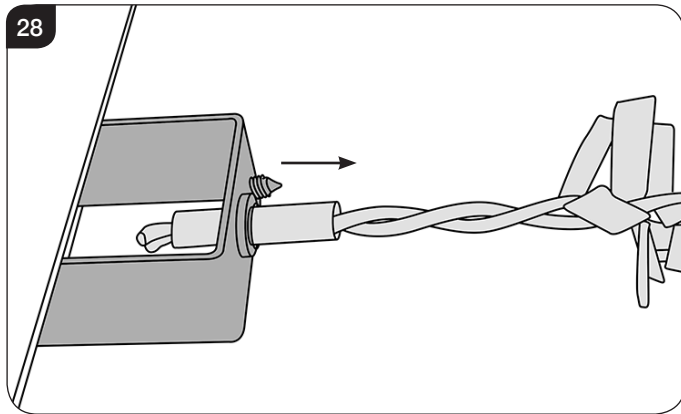

- 11.6 Replace in reverse order.

Take care not to damage the spindle blades when replacing

12. Replacing the Flame Effect LED Board



WARNING: The Effects Spindles are sharp, please use caution when servicing this appliance.

- 12.1 Follow Sections 3, 4, 5, 6, 8, 9 & 10 to access the Flame Effects LED Board.
- 12.2 Remove the screws, working from the outside in, to remove the shield(s), see Diagram 29.

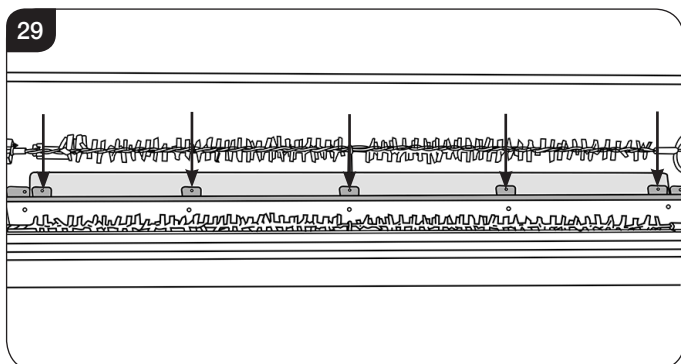

NOTE: When refitting the shield ensure that the lip curves down and towards the back. It will be necessary to lift the shield slightly to align the screws. Refit the screws from inside out.

- 12.3 The LED boards are located below the Effects Spindle, see Diagram 30.

The number of LED Boards may vary between models.

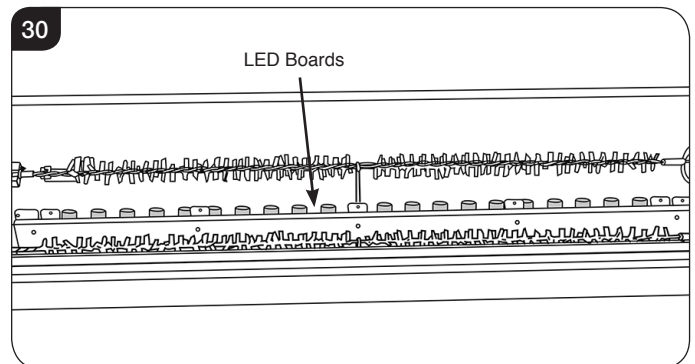

- 12.4 The LED boards are coupled together at the end of each board and held in place by clips, see Diagram 31.

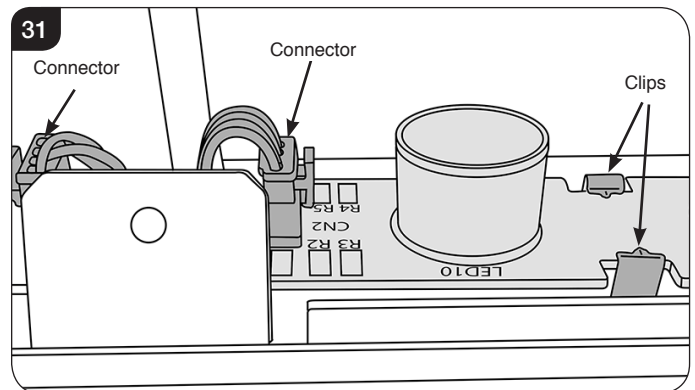

- 12.5 Unplug the correct LED board and pull the clips open to release.
- 12.6 Fitting a new board is the reverse of this process.

IMPORTANT: Test the LEDs before refitting the Fuel Bed.

The LED Boards must be connected correctly with the CN1 in and the CN2 out.

Servicing Instructions

13. Replacing the Fuel Bed Motor

- 13.1 Follow Sections 3, 5 & 6 to access the Fuel Bed Motor and its connections.
- 13.2 Remove the Effects Spindle by pulling the rubber sleeve off the Effects Motor axle, see Diagram 32.

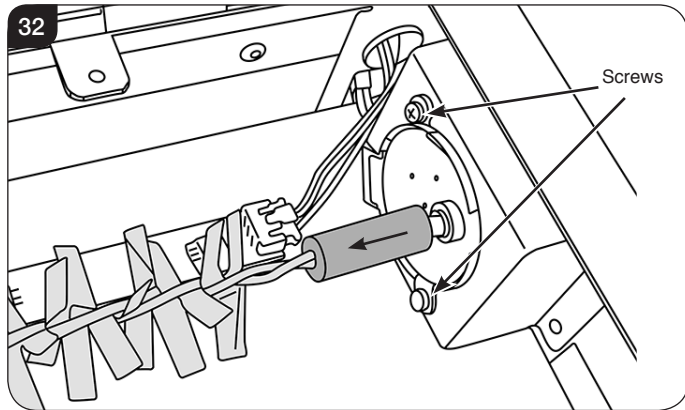

- 13.3 Remove the 2 screws to release the motor unit, see Diagram 33.
- 13.4 Follow the wires to the corresponding connector and disconnect the motor unit by squeezing the clips on each side of the plug, see Diagram 33.
NOTE: The cable clip may need to be removed to gain access to the connector, ensure this is replaced when operation is complete.

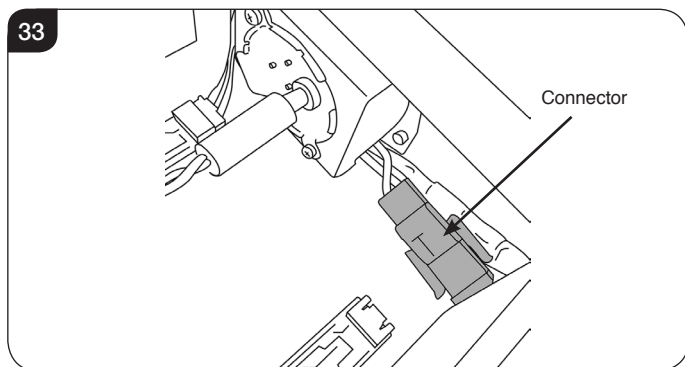

14. Replacing the Flame Effect Motor

- 14.1 Follow Sections 3, 4, 5, 6, 8 & 11 to access the Flame Effect Motor.
- 14.2 Remove the Effects Spindle by pulling the rubber sleeve off the Effects Motor axle, see Diagram 34.

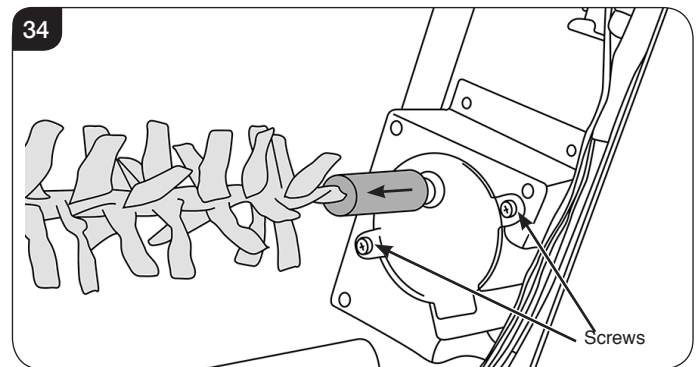

- 14.3 Remove the 2 screws to release the motor unit, see Diagram 34.
- 14.4 Follow the wires to the corresponding connector and disconnect the motor unit by squeezing the clips on each side of the plug, see Diagram 35.

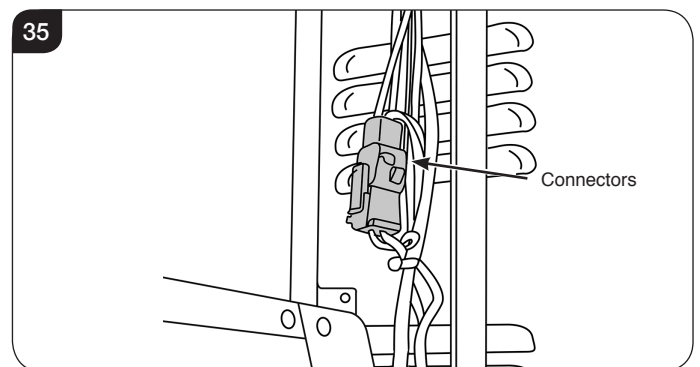

- 14.5 Replace in reverse order, ensuring the cable ties are replaced.

Servicing Instructions

15. Replacing the Power Unit

15.1 Follow Section 4 to access the Power Unit.

55R & 75R MODELS ONLY: Remove the LED Light Bar prior to replacing the Power Unit, see Section 5.

15.2 The Power Unit is held in place by 4 screws, see Diagram 36.

The Power Unit may vary slightly between models.

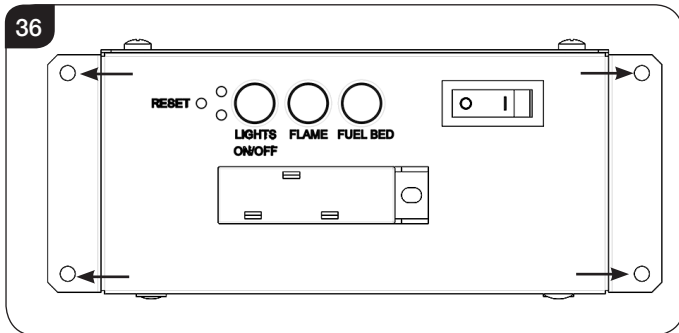

15.3 Support the Power Unit and remove the 4 screws.

15.4 The Power Unit is attached to the appliance by several cables and wiring looms, see Diagram 37.

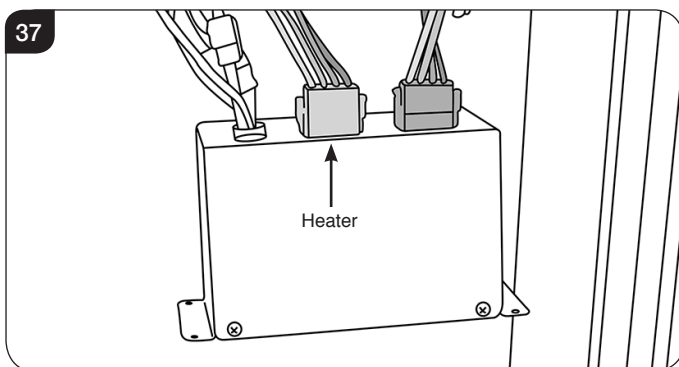

15.5 Unclip the 2 wiring looms by squeezing each side of the connectors, see Diagram 38.

15.6 Disconnect the 2 LED Board connectors and the LED Light Bar connector to detach the Power Unit from the appliance, see Diagram 38.

The Wiring Loom may vary slightly between models.

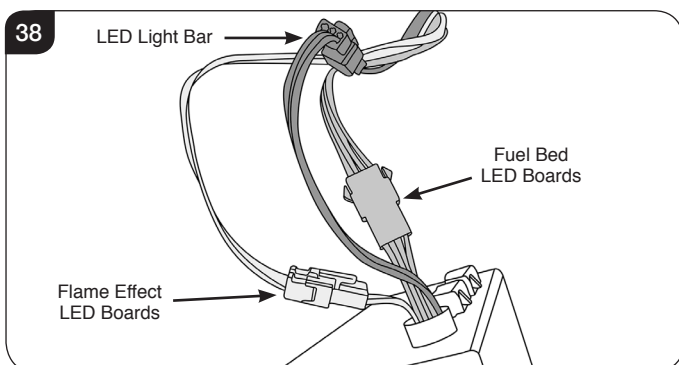

15.7 Replace in reverse order.

16. Replacing the Heater Assembly

16.1 Follow Section 4 & 5 access the Heater Assembly.

16.2 Remove the screw aligned with the centre of the heater in the front face of the appliance. The position may vary between models, see Diagram 39.

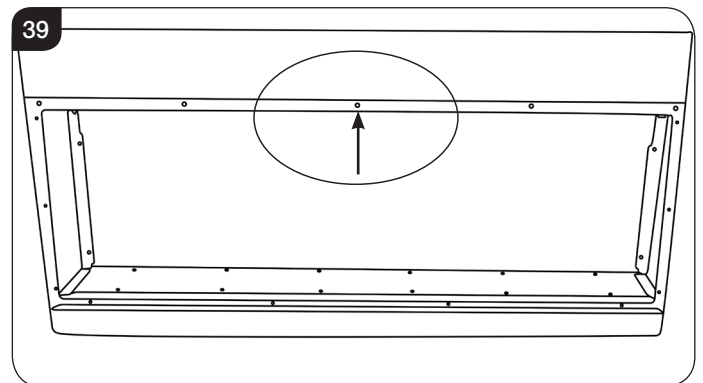

16.3 The Heater Assembly is now held in place by 5 screws at the top of the firebox. Supporting the Heater Assembly remove the screws, see Diagram 40.

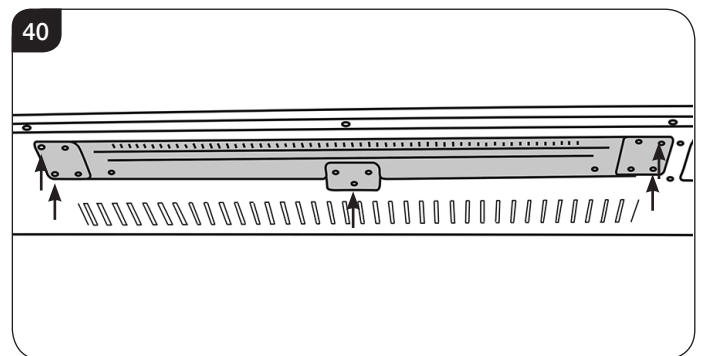

16.4 Carefully lower the Heater Assembly. This will require a slight tipping motion to clear the edge, see Diagram 41.

NOTE: The Heater Assembly has wires attached.

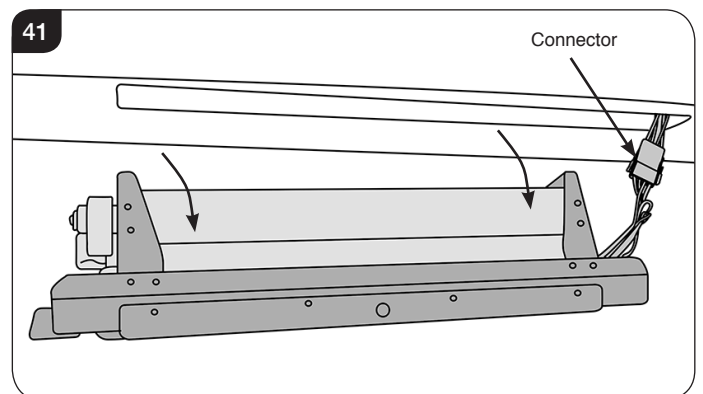

16.5 Carefully feed the wires over the between the Heater Assembly and Power Unit apertures.

Servicing Instructions

16.6 Replace the Heater Assembly.

NOTE: When replacing the Heater Unit the back should be installed first, and a slight tipping motion will be required to clear the edge.



17. Pairing the Remote Control to the Appliance

Signal Code

The below operations should be carried out before coding when changing to a new remote or the unit cannot be controlled by the remote:

The reset button is located on the control panel located on the right-hand side of the viewing window, see Diagram 44.

- 17.1 Press the reset button for 3 seconds (a pen point may be needed) until 3 short beeps sound from the unit, release the button.

Within 10 seconds, press the  button on remote. The coding is finished when 1 long beep sounds from the unit.

The Power Unit may vary slightly between models.

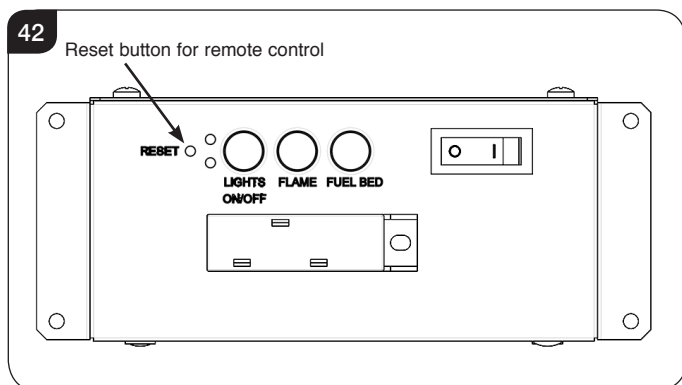

Resetting of the remote control is necessary if the appliance operates wrongly due to external interference signal and the remote control is not in use.

18. Resetting the Remote

Resetting the Remote may necessary if the appliance operates incorrectly under the signal from the Remote, or if the Remote does not operate correctly.

- 18.1 Open the back cover of the Remote.
- 18.2 Press the Reset button for 3 seconds and reset the coding, see Diagram 43.

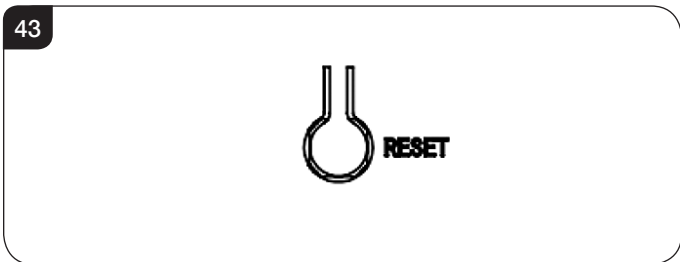

GAZCO

Wiring Diagram

All Models

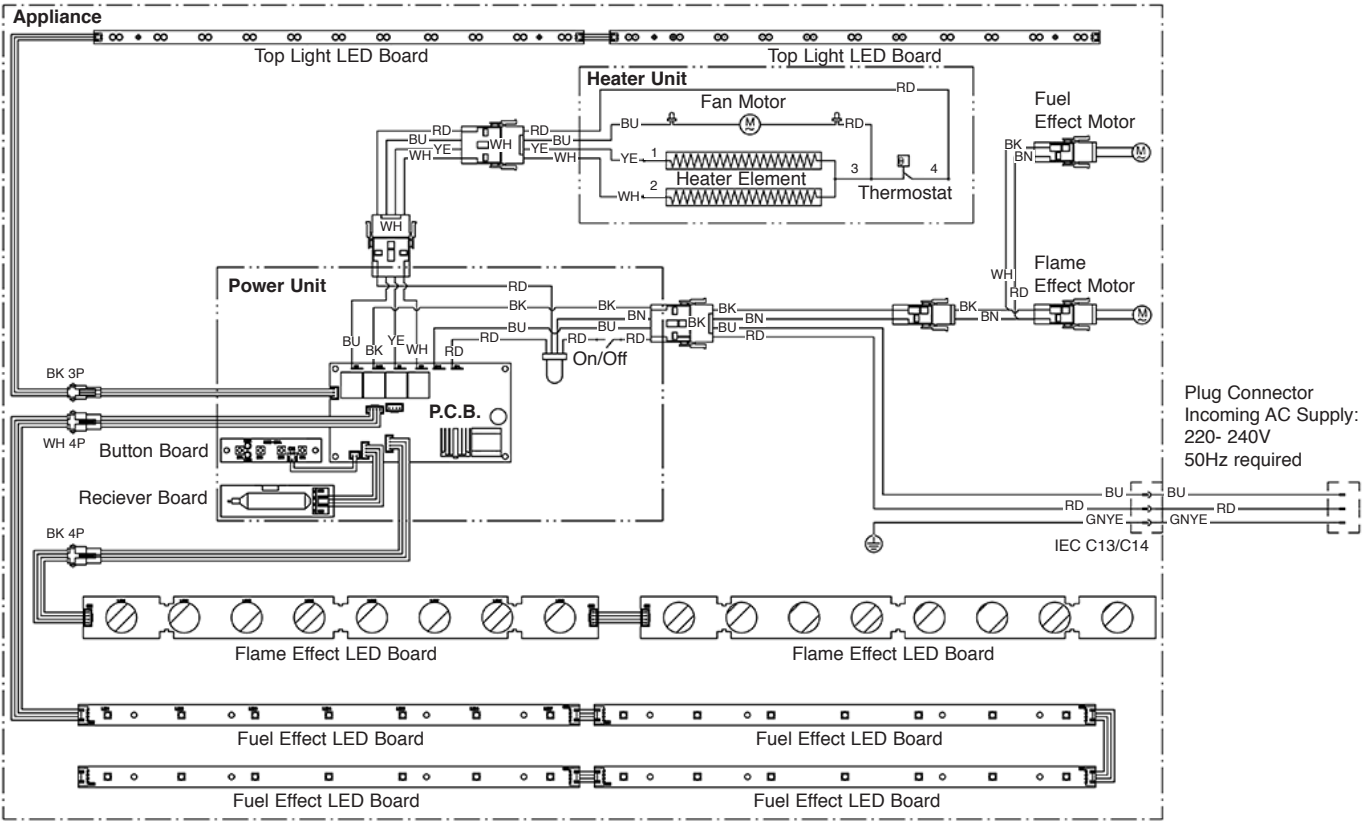

The number of LED Boards varies depending on the model

Colour Codes	
RD	RED
BU	BLUE
YE	YELLOW
WH	WHITE
BK	BLACK
BN	BROWN
GNYE	GREEN & YELLOW

Spare Parts List

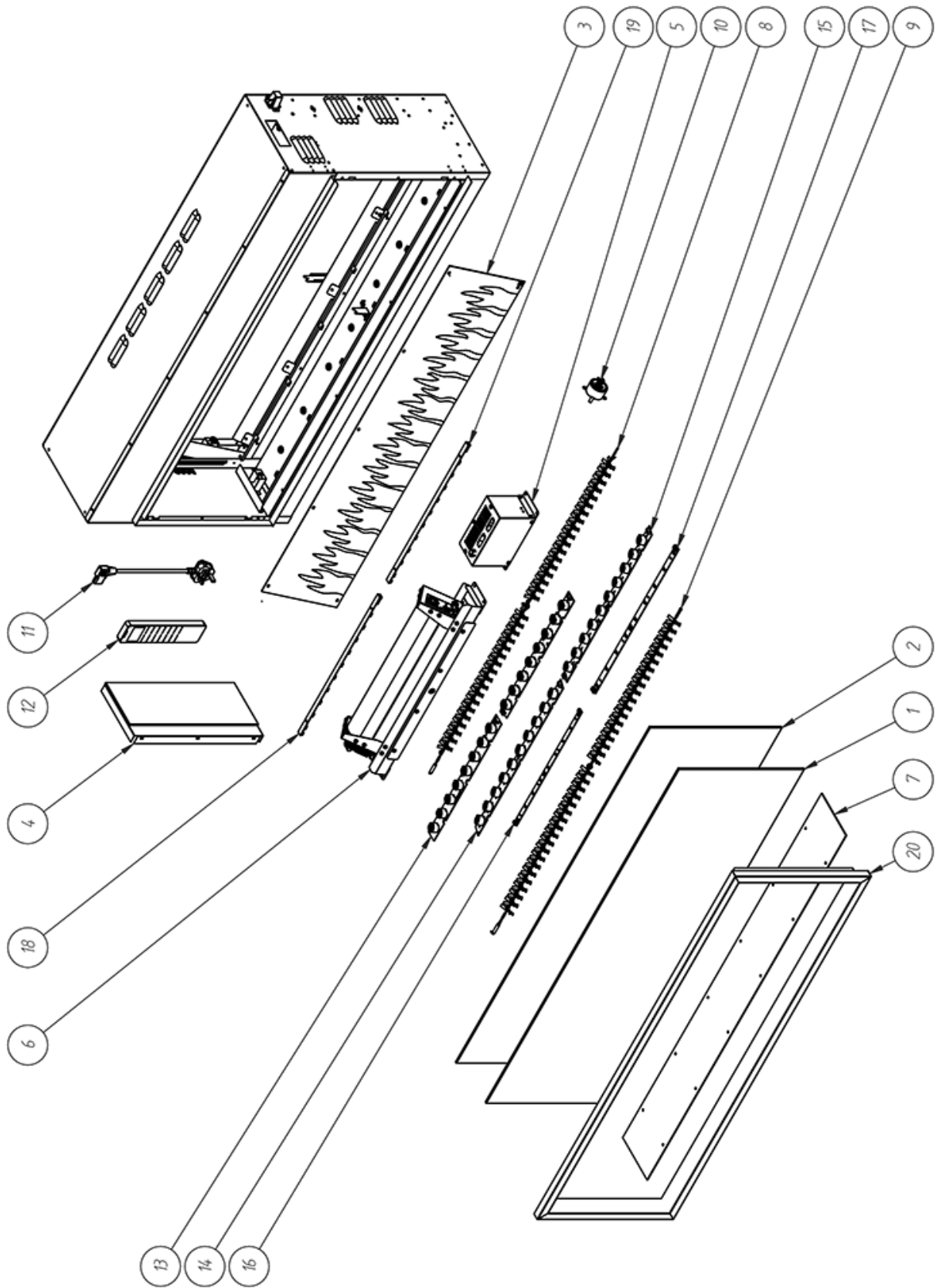

No.	Component	55R			75R			85R		
		Part Code	LED Board Identifier	Quantity	Part Code	LED Board Identifier	Quantity	Part Code	LED Board Identifier	Quantity
1	Front Glass Panel	CE2006		1	CE2008		1	CE1891		1
2	Display Screen	CE2007		1	CE2009		1	CE1897		1
3	Flame Effect Screen	PL0220		1	PL0221		1	PL0195		1
4	Side Panel	GZ15365		2	GZ15366		2	GZ14632		2
5	Power Unit	EL0778		1	EL0711		1	EL0711		1
6	Heater Unit	EL0792		1	EL0792		1	EL0792		1
7	Fuel Bed	PL0224		1	PL0225		1	PL0201		1
8	Flame Effect Spindle	EL0795		1	EL0796		1	EL0700		1
9	Fuel Effect Spindle	EL0793		1	EL0794		1	EL0706		1
10	Spindle Motor	EL0713		2	EL0713		2	EL0713		2
11	Power Cable	EL0549		1	EL0549		1	EL0549		1
12	Remote Handset C	EL0678		1	EL0678		1	EL0678		1
13	Flame Effect LED Board 1	EL0723	RC07-180B	1	EL0718	RC07-157A	1	EL0718	RC07-157A	1
14	Flame Effect LED Board 2	-		-	EL0722	RC07-193A	1	EL0722	RC07-193A	1
15	Flame Effect LED Board 3	-		-	-		-	-		-
16	Fuel Bed LED Board 1	EL0725	RC07-169A	2	EL0727	RC07-137A	4	EL0727	RC07-137A	4
17	Fuel Bed LED Board 2	-		-	-		-	-		-
18	Downlight LED Board 1	EL0716	RC07-168A	1	EL0717	RC07-179A	2	EL0715	RC07-192A	2
19	Downlight LED Board 2	-		-	-		-	-		-
20	Magnetic Front Trim	GZ15367		1	GZ15368		1	GZ14628		1

No.	Component	105R			135R			195R		
		Part Code	LED Board Identifier	Quantity	Part Code	LED Board Identifier	Quantity	Part Code	LED Board Identifier	Quantity
1	Front Glass Panel	CE1892		1	CE1893		1	CE1894		1
2	Display Screen	CE1898		1	CE1899		1	CE1900		1
3	Flame Effect Screen	PL0196		1	PL0197		1	PL0198		1
4	Side Panel	GZ14632		2	GZ14632		2	GZ14632		2
5	Power Unit	EL0711		1	EL0711		1	EL0711		1
6	Heater Unit	EL0792		1	EL0792		1	EL0792		1
7	Fuel Bed	PL0202		1	PL0203		1	PL0204		1
8	Flame Effect Spindle	EL0701		1	EL0702		1	EL0703		1
9	Fuel Effect Spindle	EL0707		1	EL0708		1	EL0709		1
10	Spindle Motor	EL0713		2	EL0713		2	EL0713		2
11	Power Cable	EL0549		1	EL0549		1	EL0549		1
12	Remote Handset C	EL0678		1	EL0678		1	EL0678		1
13	Flame Effect LED Board 1	EL0720	RC07-167B	1	EL0718	RC07-157A	1	EL0720	RC07-167B	1
14	Flame Effect LED Board 2	EL0721	RC07-191A	1	EL0722	RC07-193A	1	EL0721	RC07-191A	1
15	Flame Effect LED Board 3	-		-	EL0719	RC07-167A	1	EL0719	RC07-167A	2
16	Fuel Bed LED Board 1	EL0726	RC07-125A	4	EL0726	RC07-125A	2	EL0726	RC07-125A	8
17	Fuel Bed LED Board 2	-		-	EL0727	RC07-137A	4	-		-
18	Downlight LED Board 1	EL0716	RC07-168A	2	EL0716	RC07-168A	1	EL0716	RC07-168A	4
19	Downlight LED Board 2	-		-	EL0715	RC07-192A	2	-		-
20	Magnetic Front Trim	GZ14629		1	GZ14630		1	GZ14631		1



Due to continual technical improvements please check online or with your Gazco retailer for the most up to date parts lists.

Only use Genuine Gazco spares when servicing your appliance.

All of our essential spare parts and consumable items are available to purchase from our webshop at www.gazcospares.com.

Warranty

Limited Warranty

FPI Fireplace Products International Ltd. ("the distributor") through its wholly owned subsidiary, Fireplace Products Australia Pty Ltd and sold under the Gazco brand of fireplace products, extends this Limited Warranty to the original purchaser of this appliance provided the product remains in the original place of installation.

Some conditions apply (see below).

The policy is not transferable, amendable or negotiable under any circumstances.

After the original warranty coverage for any of the parts above have expired, any repair and/or replacement parts purchased by the consumer from FPI or through an accredited distributor or dealer will carry a ninety (90) day warranty (valid only with an original copy of the tax invoice). No labor coverage is included with any repair and/or replacement part.

Replacement parts are limited to one per warranty term.

Exclusions

This Limited Warranty does not extend to paint, rust or corrosion of any kind due to a lack of maintenance or improper venting, combustion air provision, corrosive chemicals (i.e. chlorine, salt, air, etc.), firebrick (rear, sides or bottom), door or glass gasket, or any other additional factory fitted gasket.

Malfunction, damage or performance based issues as a result of environmental conditions, location, chemical damages, downdrafts, installation error, installation by an unqualified installer, incorrect chimney components (including but not limited to cap size or type), operator error, abuse, misuse, use of improper fuels (such as unseasoned timber, mill-ends, construction timber or debris, off-cuts, treated or painted timber, tea tree, metal or foil, plastics, garbage, solvents, cardboard, coal or coal products, oil based products, waxed cartons, compressed pre-manufactured logs), accidents, lack of regular maintenance and upkeep, acts of God, weather related problems from hurricanes, tornados, earthquakes, floods, lightning strikes/bolts or acts of terrorism or war, which result in malfunction of the appliance are not covered under the terms of this Limited Warranty.

FPI has no obligation to enhance or modify any unit once manufactured (i.e. as products evolve, field modifications or upgrades will not be performed on existing appliances).

Any unit showing signs of neglect or misuse will not be covered under the terms of this warranty policy and may void this warranty. This includes units with rusted or corroded fireboxes which have not been reported as rusted or corroded within three (3) months of installation/purchase. Any alteration to the unit which causes sooting or carboning that results in damage to the exterior fascia or over firing that can cause component or firebox/heat exchanger failure will not be covered by this warranty.

Units which show evidence of being operated while damaged, or with problems known to the purchaser and causing further damages will void this warranty.

Units where the serial no. has been altered, deleted, removed or made illegible will void this warranty.

Minor movement, expansion and contraction of the steel is normal and is not covered under the terms of this warranty.

Freight damages for products or parts are not covered under the terms of the warranty.

Porcelain/Enamel: Absolute perfection is neither guaranteed nor commercially possible. Any chips must be reported and inspected by the authorised selling dealer within three (3) days of installation. Any damage of this type not reported after this time period will be subject to rejection and any related warranty will not apply.

Special Finishes: Expect some changes in color as the product "ages" with constant heating and cooling. The manufacturer warranty does not cover tarnishing, changing colors and/or marks (i.e. finger prints, etc.) after the purchase of the product. Damage from the use of abrasive cleaners is not covered by warranty.

Products made or provided by other manufacturers and used in conjunction with the FPI appliance without prior authorisation from FPI may void this warranty.

INCORRECT INSTALLATION IS NOT COVERED BY WARRANTY. A SERVICE OR CALLOUT FEE WILL BE CHARGED IN THESE CIRCUMSTANCES.

Limitations of Liability

1. Exclusion of implied terms

The customer may have the benefit of consumer guarantees under the Australian Consumer Law. To the maximum extent permitted by law, all terms, conditions or warranties that would be implied into this Warranty or in connection with the supply of any goods or services by the supplier under law or statute or custom or international conventions are excluded.

2. Limitation of liability

(a) To the maximum extent permitted by law and subject to clauses 1 and 3, the supplier's total liability arising out of or in connection with its performance or its obligations pursuant to this Warranty, or arising out of or in connection with the supply of specific goods or services (including pursuant to or for breach of this Warranty, under statute, in equity or for tort, including negligent acts or omissions) is limited as follows: (i) the supplier shall have no liability to the customer for any Consequential Loss; (ii) without limiting the effect of clause 2(a)(i), the supplier's total aggregate liability for Loss, however arising, shall not exceed the GST exclusive aggregate price paid by the customer to the supplier for the specific goods or services that gave rise to the Loss in question.

(b) The limitations and exclusions in this sub-clause do not apply to the extent that any Loss is directly attributable to: (i) the personal injury or death caused by the supplier's default, breach of this Warranty or negligence; or (ii) fraud by the supplier.

(c) Each party must take reasonable steps to mitigate any Loss it suffers or incurs.

3. Limitation of liability under Australian Consumer Law Guarantees

(a) To the extent that goods supplied by the supplier are not goods of a kind ordinarily acquired for personal, domestic or household use and the customer is deemed to be a consumer for the purposes of section 64A of the Australian Consumer Law, the customer agrees that the supplier's liability for a failure to comply with a consumer guarantee that the customer may have a benefit under the Australian Consumer Law (other than a guarantee under sections 51 (title), 52 (undisturbed possession) and 53 (undisclosed securities)), is limited to, at the option of the supplier, one or more of the following: (i) replacement of the goods or the supply of equivalent goods; (ii) the repair of the goods; (iii) the payment of the cost of replacing the goods or of acquiring equivalent goods; or (iv) equivalent goods; or (v) the payment of the cost of having the goods repaired.

(b) To the extent that services supplied by the supplier are services other than services of a kind ordinarily acquired for personal, domestic or household use or consumption, the supplier's liability for failure to comply with a consumer guarantee that the customer may have the benefit of is limited to, at the option of the supplier: (i) the supply of the services again; or (ii) the payment of the cost of having the services supplied again.

4. Subject to Change

This Limited Warranty is given at the time of sale and purchase of the relevant fireplace product. The terms of this Limited Warranty may be amended from time to time by FPI in accordance with changes to business practices, consumer laws or other legal requirements. The rights and protections granted under the Limited Warranty are those in force in relation to a fireplace product at the time and in the place of sale of that product, and only those terms will be applicable in respect of that product.

5. Severability

Any term of this Limited Warranty that is invalid or unenforceable in any jurisdiction is to be read down for the purposes of that jurisdiction, if possible, so as to be valid and enforceable, and is otherwise capable of being severed to the extent of the invalidity or unenforceability, without affecting the remaining provisions of this Limited Warranty or affecting the validity or enforceability of that provision in any other jurisdiction.

6. Definitions

For purposes of clauses 1, 2 and 3:

(a) Consequential Loss means loss of expected savings, loss of use, loss of opportunity, loss of profit, loss of revenue, increased financing costs, loss arising from delay, or any consequential, special or indirect loss or damage, whether or not the possibility or potential extent of the loss or damage was known or foreseeable, and whether arising from a claim under indemnity, contract, tort (including negligence), statute or otherwise.

(b) Loss means any expense, cost or damage of any kind and includes Consequential Loss and a fine or penalty imposed by a statutory or other authority.

Distributed by:

Australia

Fireplace Products Australia Pty Ltd
99 Colemans Road
Dandenong, South VIC, 3175
AUSTRALIA
+613 9799 7277
www.regency-fire.com.au

New Zealand



Head Office & Showroom
12 Tawari Street
Mt Eden, Auckland, New Zealand
+649 623 6990
thefireplace.co.nz

Manufactured by

Gazco Limited, Osprey Road, Sowton Industrial Estate, Exeter, Devon, England EX2 7JG
Technical Customer Services (01392) 261950 Fax: (01392) 261951
E-mail: technicalservices@gazco.com

A member of the Stovax Group
Translated from English Issue 6

